

Footprints for Res. & Cap. different then 0402 are specified in red color near components

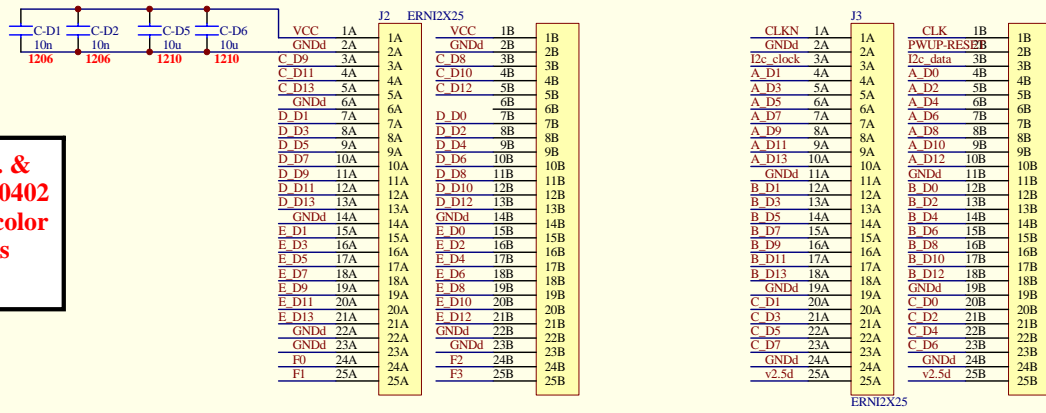

VFE to FE connectors

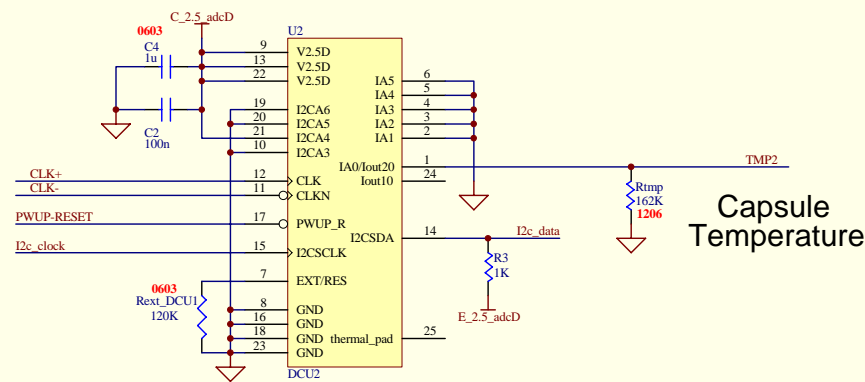
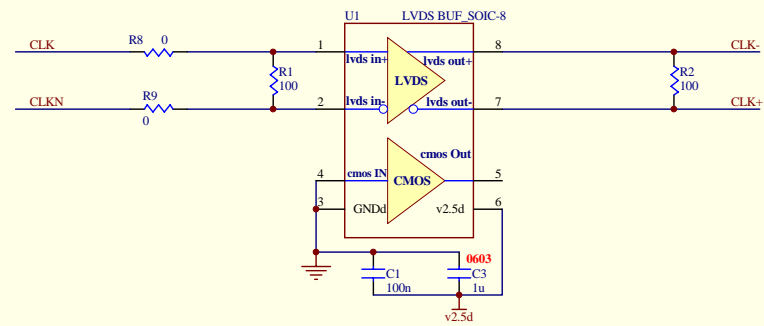
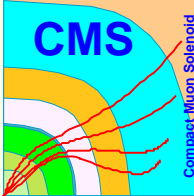

VFE to Mother Board

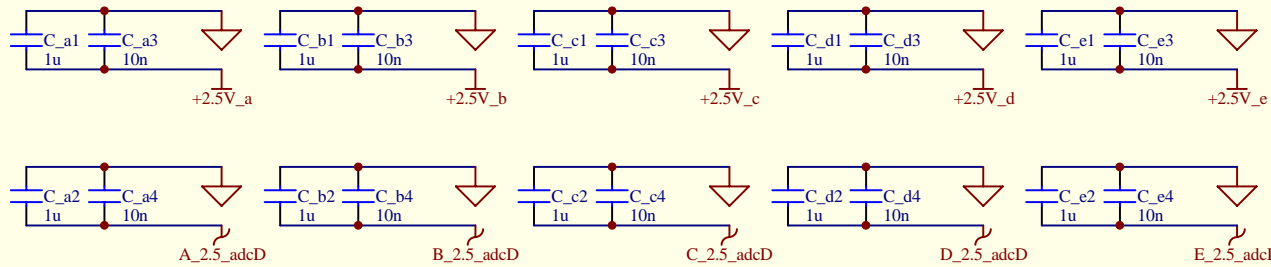
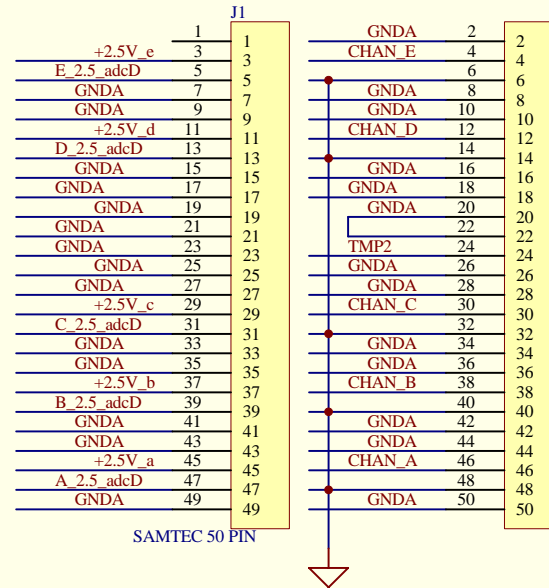

Footprint Capacitors 0603

VFE MB

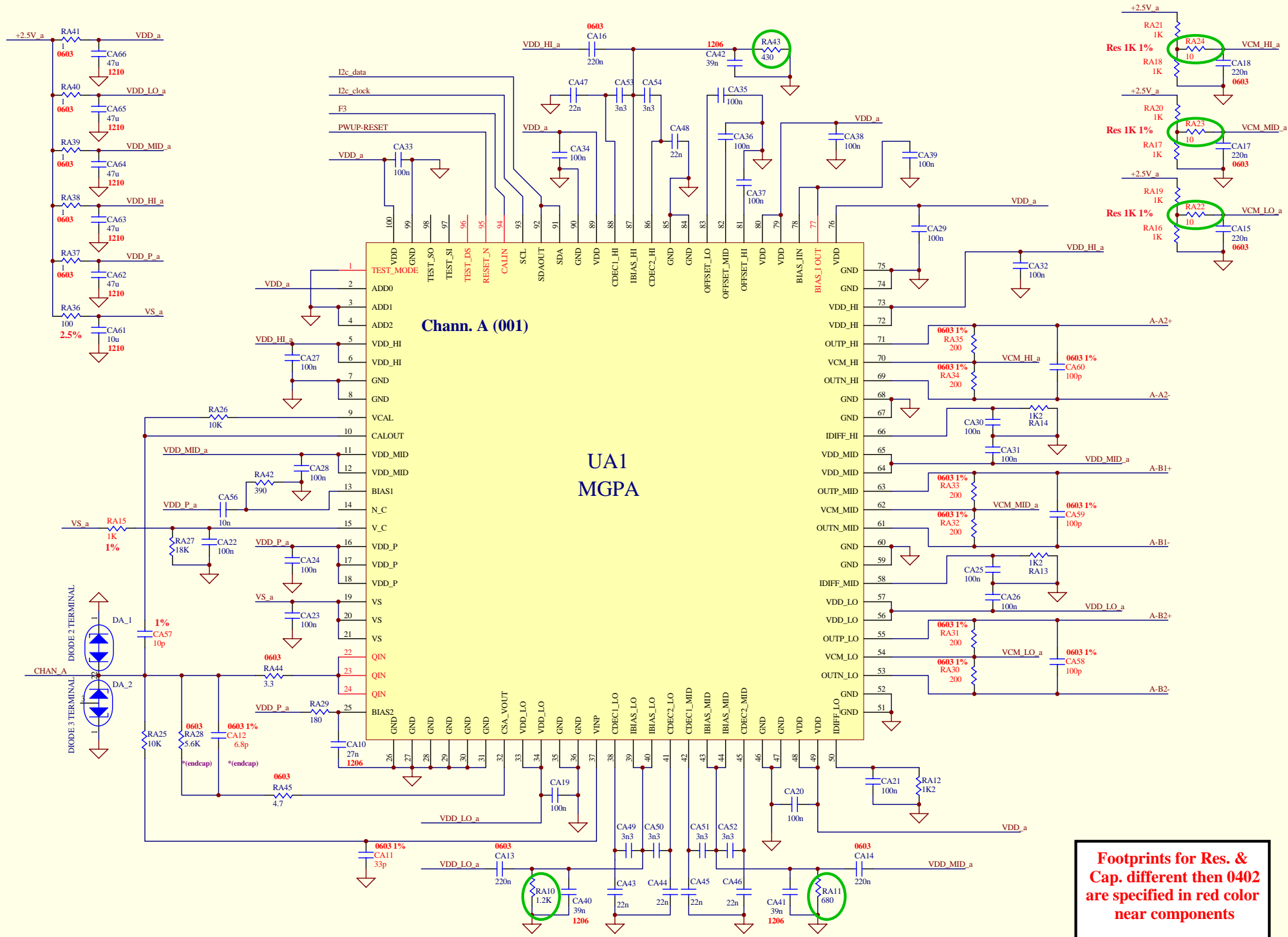

Chann. A (001)

UAI
MGPA

Footprints for Res. & Cap. different then 0402 are specified in red color near components

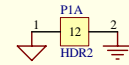

Analog & Digital GND Connection

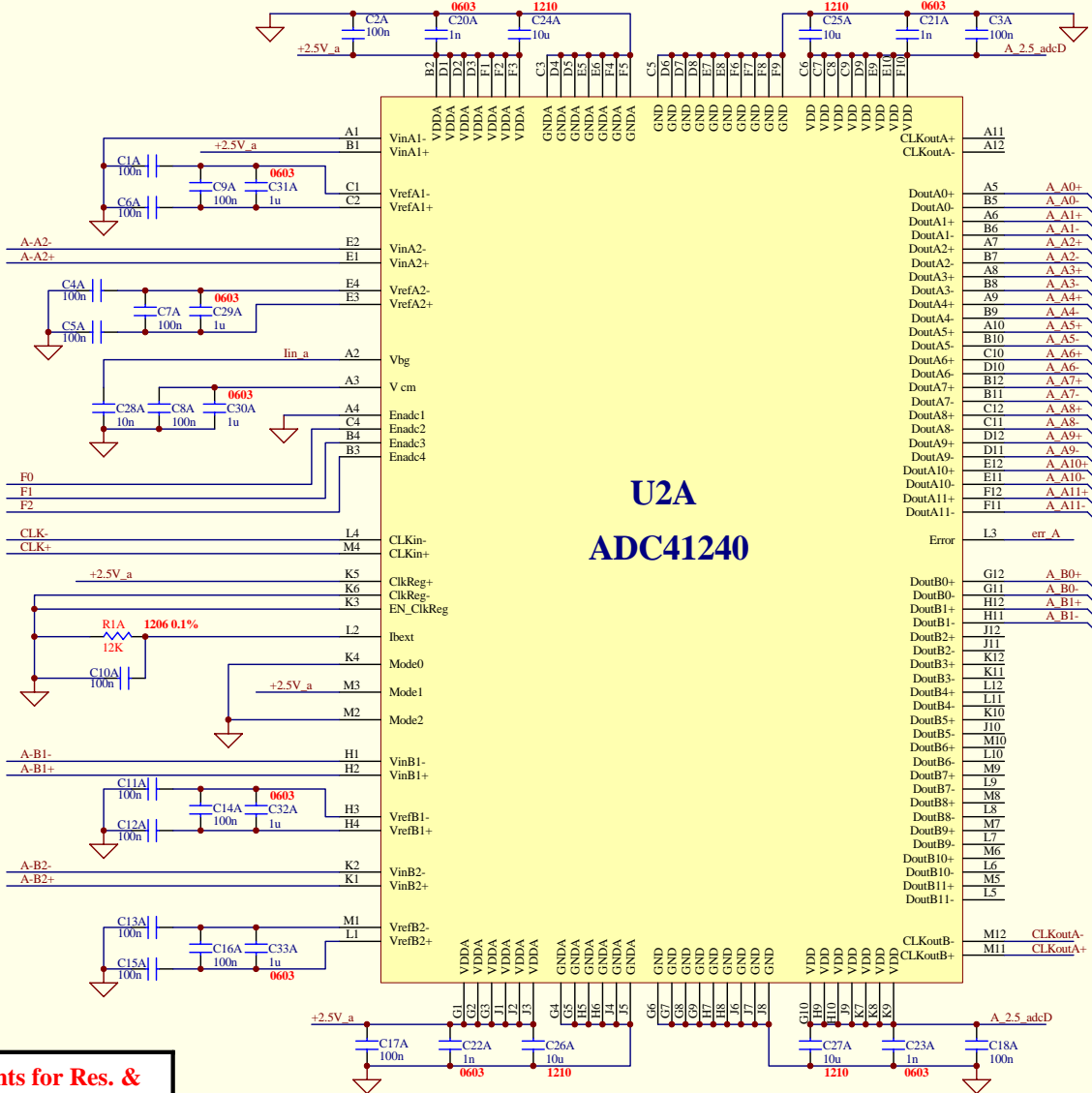

Footprints for Res. & Cap. different then 0402 are specified in red color near components

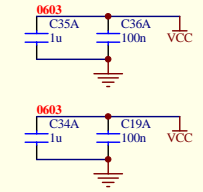
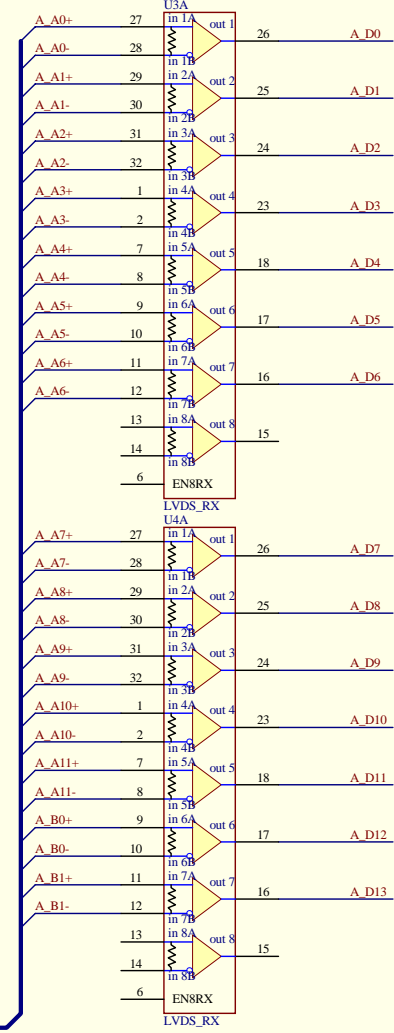

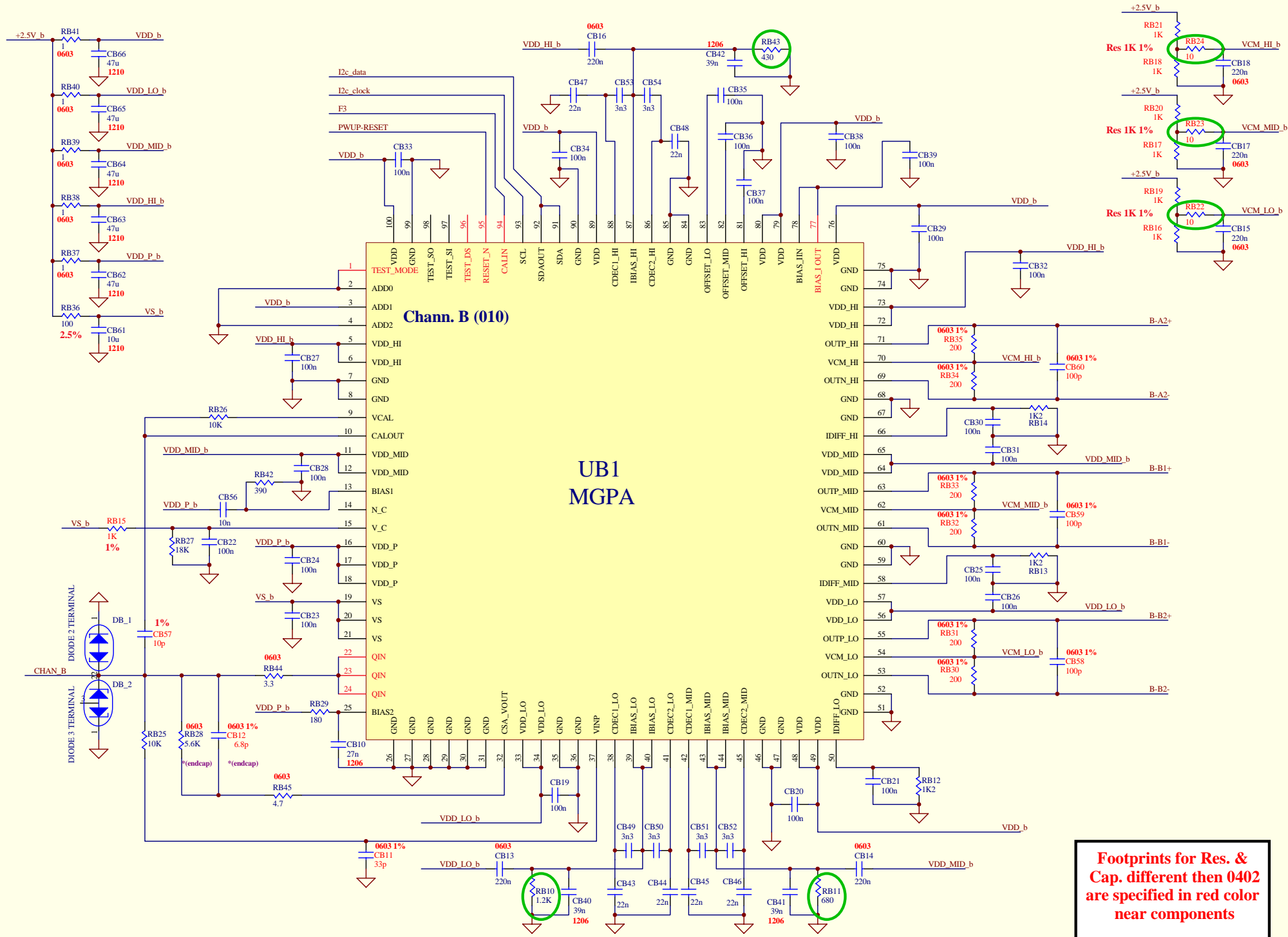

Chann. B (010)

UB1
MGPA

Footprints for Res. & Cap. different then 0402 are specified in red color near components

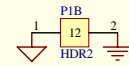

Analog & Digital GND Connection

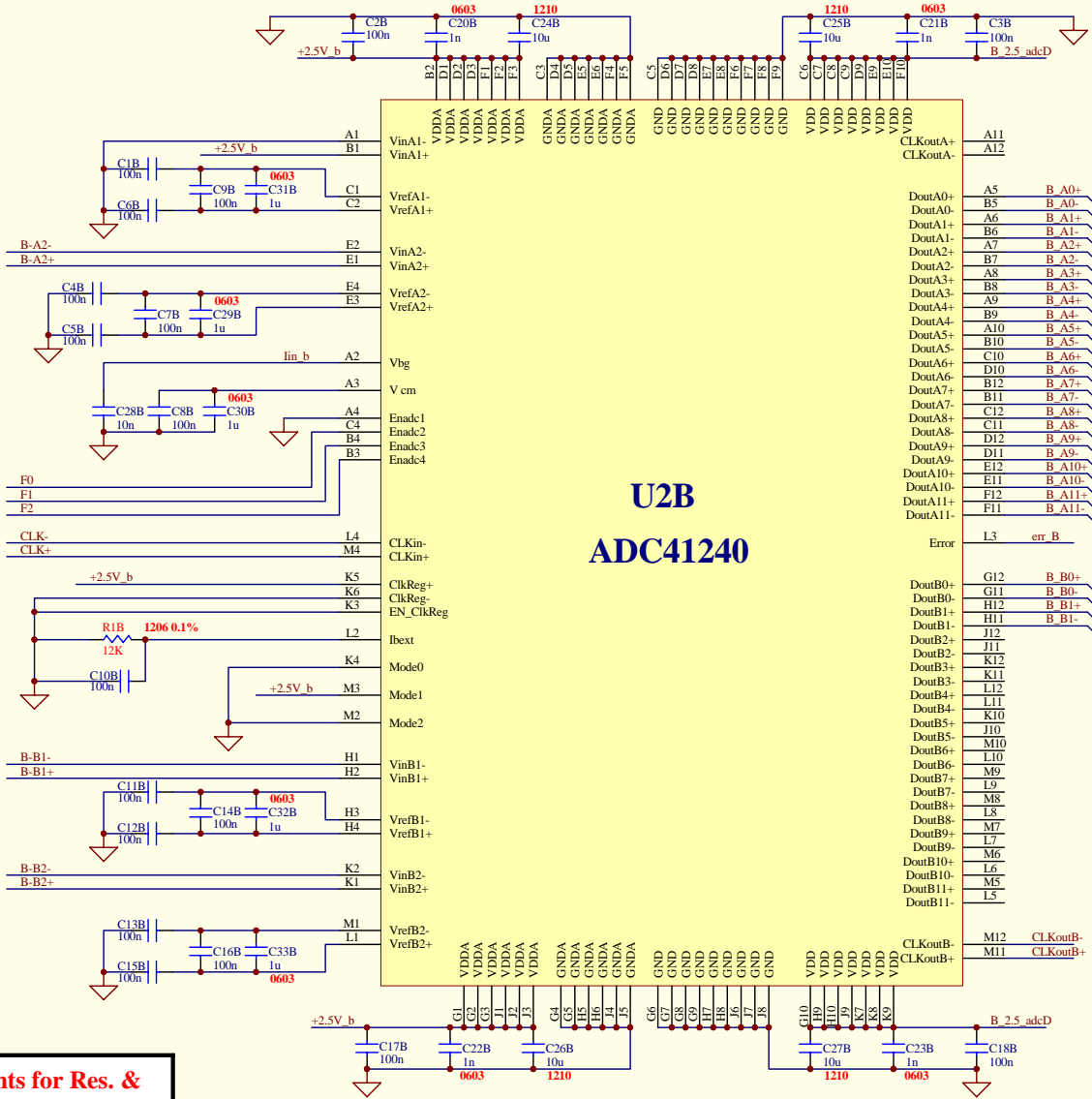

Footprints for Res. & Cap. different than 0402 are specified in red color near components

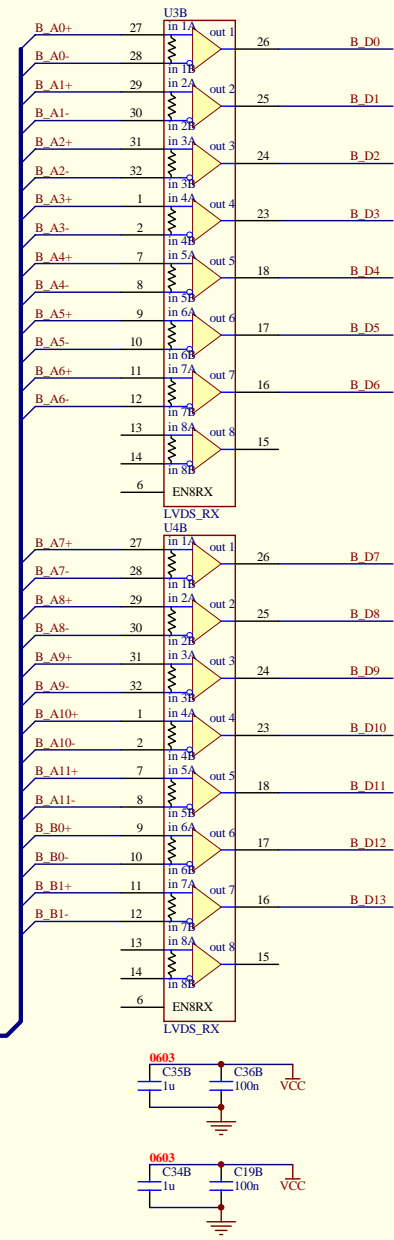

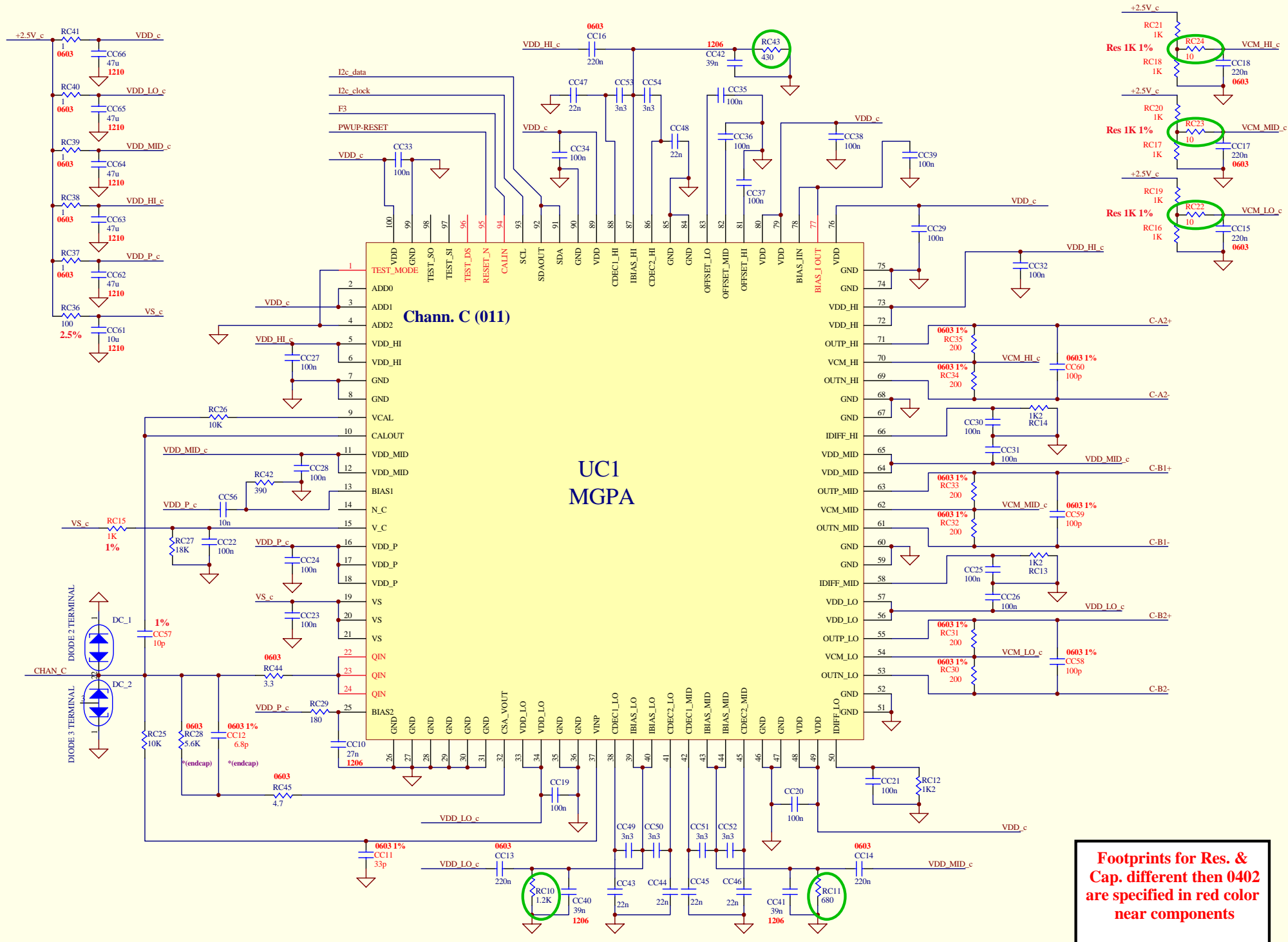

Chann. C (011)

UC1
MGPA

Footprints for Res. & Cap. different then 0402 are specified in red color near components

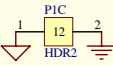

Analog & Digital GND Connection

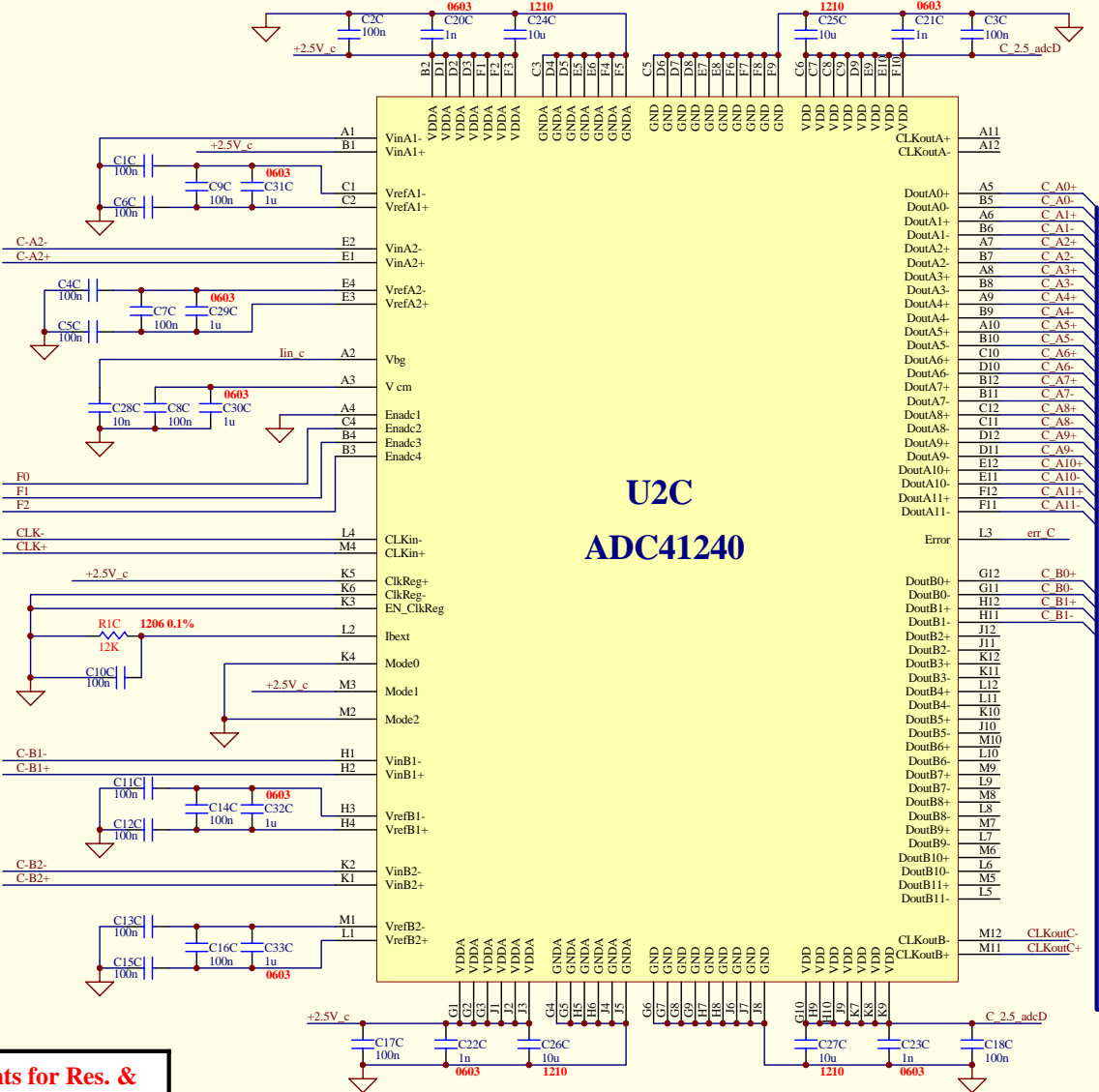

Footprints for Res. & Cap. different than 0402 are specified in red color near components

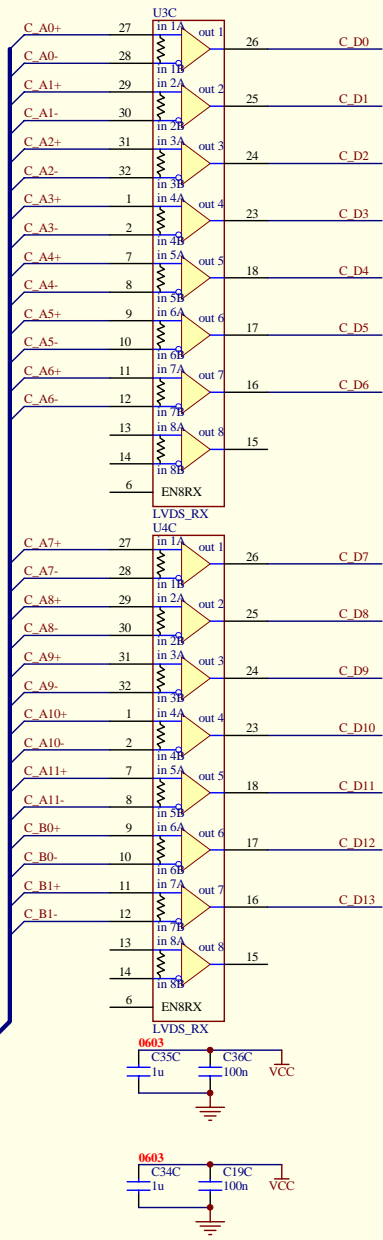

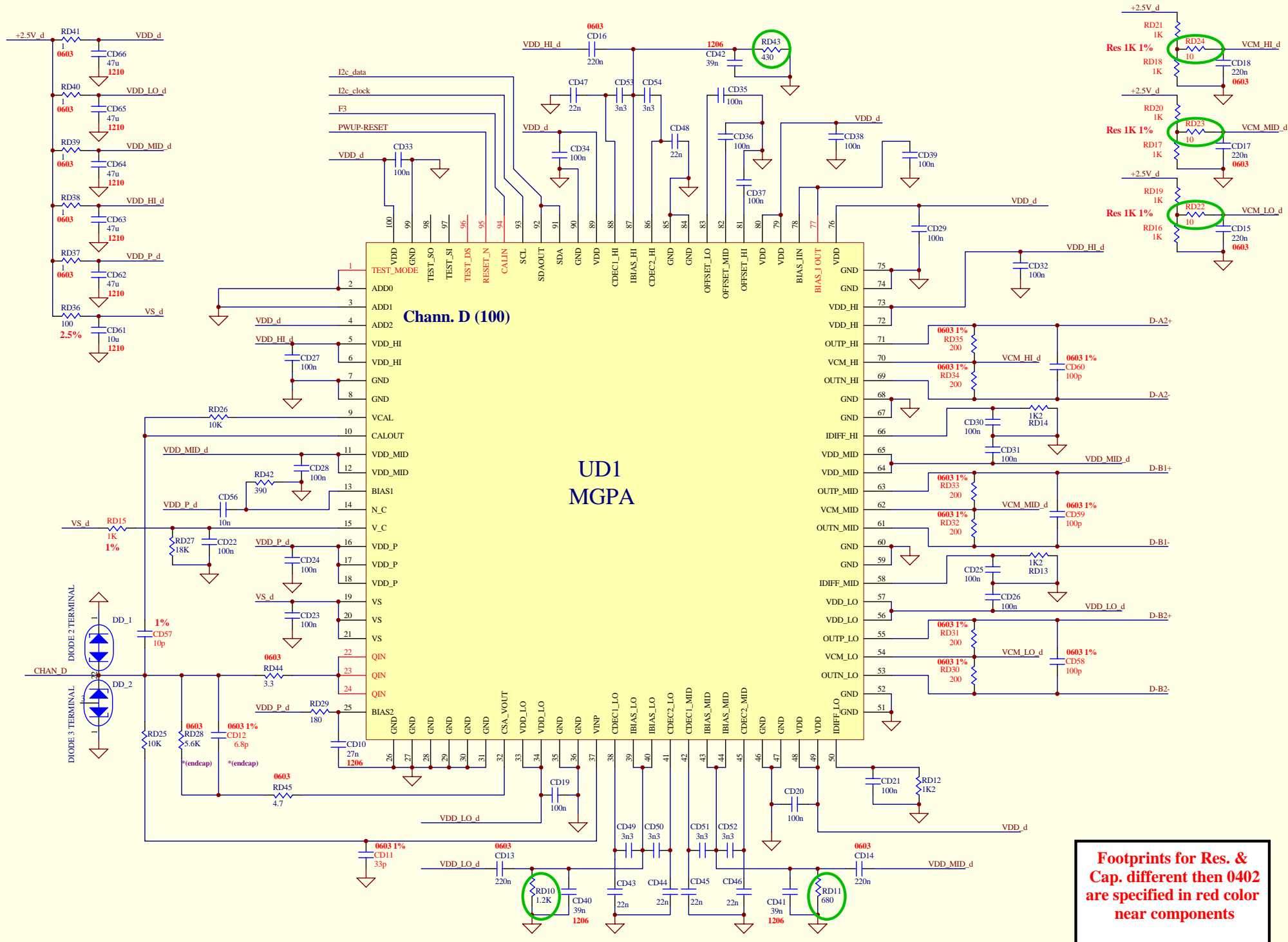

Chann. D (100)

UD1
MGPA

Footprints for Res. & Cap. different then 0402 are specified in red color near components

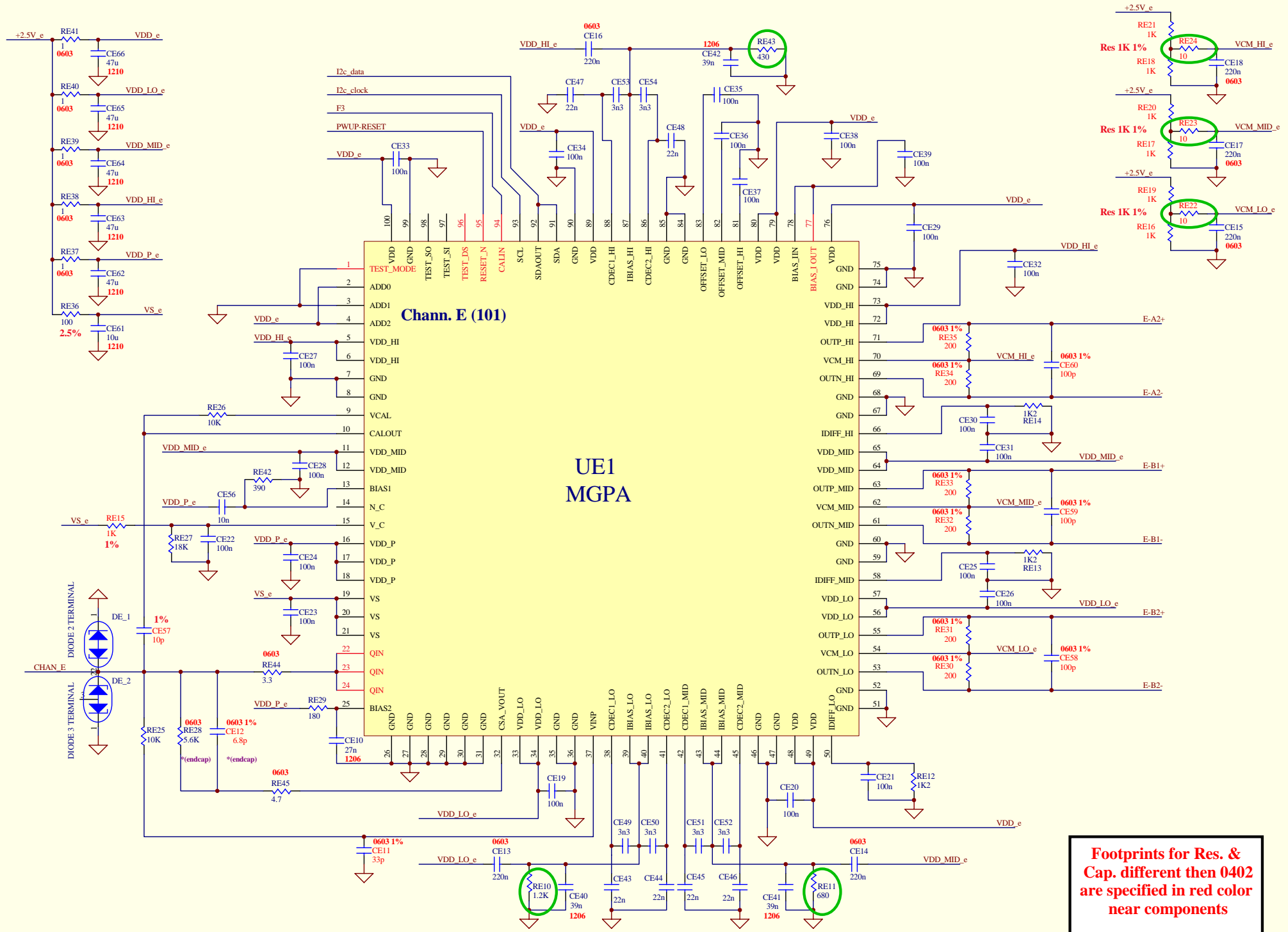

Footprints for Res. & Cap. different then 0402 are specified in red color near components



Analog & Digital GND Connection

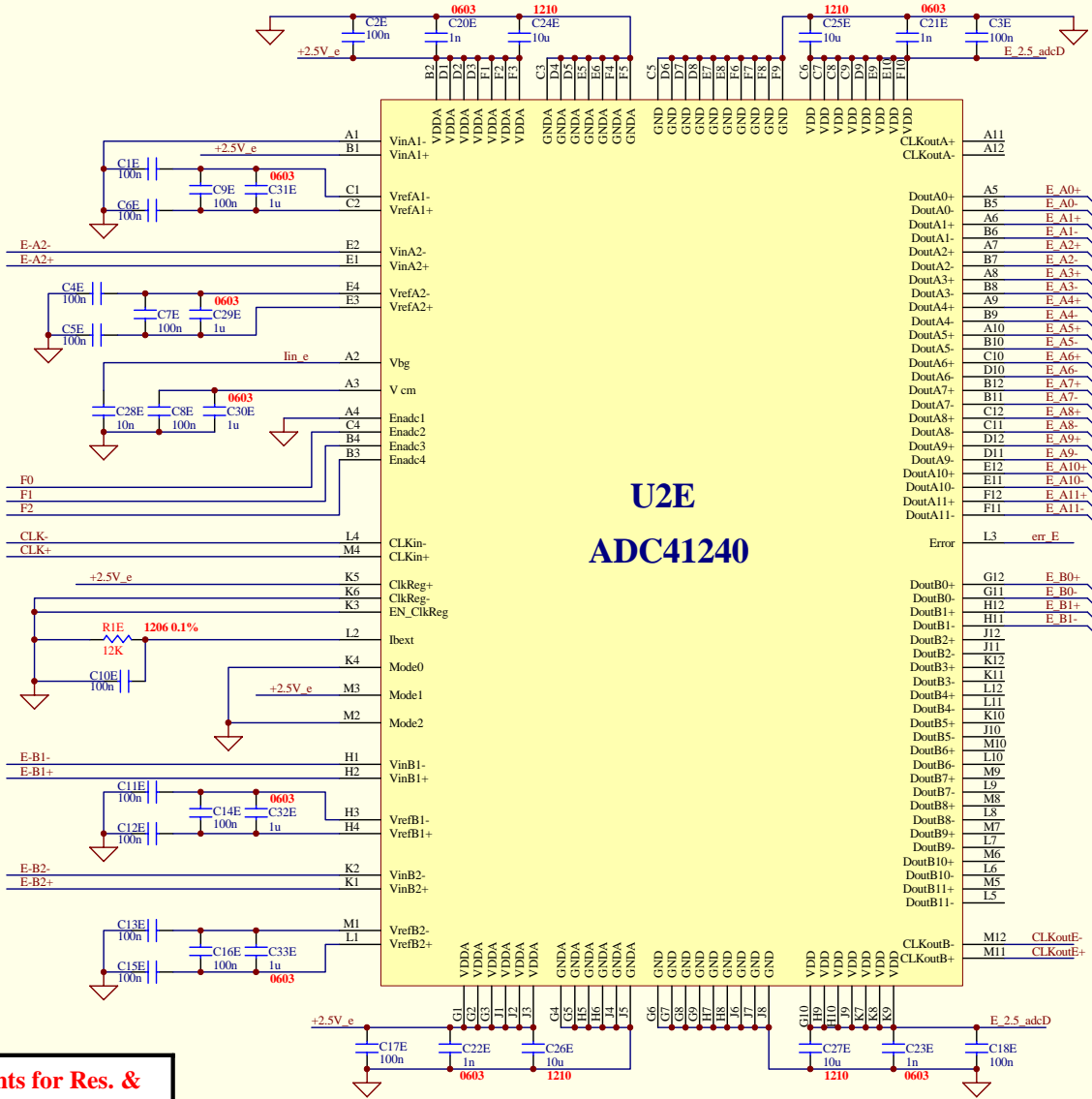

Footprints for Res. & Cap. different then 0402 are specified in red color near components

