

Thu Aug 17	16:42:14	2005					
D. CUSSANS							
ISSUE	DATE	MOD NO.	DRN BY.	CHKD.	APPD.	STATUS	
USED ON							
UOB-HEP 20 06							
UOB-HEP <small>UNIVERSITY OF BRISTOL HIGH ENERGY PHYSICS GROUP</small> H.H.WILLS PHYSICS LAB, TYNDALL AVE, BRISTOL, BS8 1TL.							
TITLE uob_hep_pc019a_lib MODULE: pc019a_readout SUPPLIES AC STIMULUS TO PROBE-BOARD TAKES DIFFERENTIAL SIGNALS FROM PROBE-BOARD AND UMBILICAL-BOARD SYNCHRONOUSLY-RECTIFIES SIGNALS							
A 2				MODULE PAGE: 1 OF 3 OVERALL PAGE: 1 OF 27			
<small>TOTAL NO. OF SHEETS</small>							

A 2 THIS DRAWING DOES NOT CONFORM TO B.S. 3939

LOGIC SIGNALS TO DRIVE THE HV SWITCH BOARD

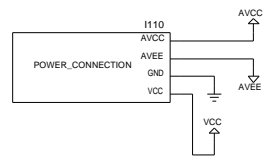
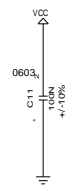
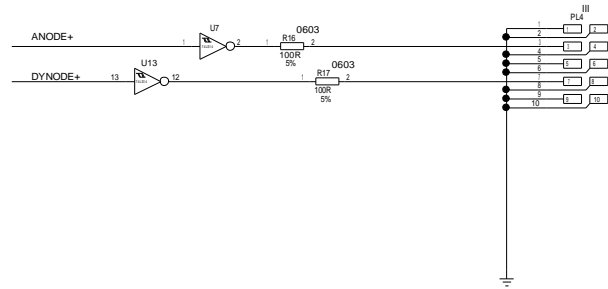

Wed Aug 23	14:54:49	2006						
			D. CUSSANS					
ISSUE	DATE	MOD NO.	DRN BY:	CHKD.	APPD.	STATUS		
USED ON							© UOB-HEP 20 06	
UOB-HEP			H.H.WILLS PHYSICS LAB, TYNDALL AVE, BRISTOL, BS8 1TL.					
UNIVERSITY OF BRISTOL HIGH ENERGY PHYSICS GROUP								
TITLE: uob_hep_pc019a_lib								
MODULE: pc019a_readout								
SUPPLIES AC STIMULUS TO PROBE-BOARD TAKES DIFFERENTIAL SIGNALS FROM PROBE-BOARD AND UMBILICAL-BOARD SYNCHRONOUSLY-RECTIFIES SIGNALS								
A 2						MODULE PAGE: 2 OF 3 OVERALL PAGE: 2 OF 27		
TOTAL NO. OF SHEETS								

A 2 THIS DRAWING DOES NOT CONFORM TO B.S. 3939

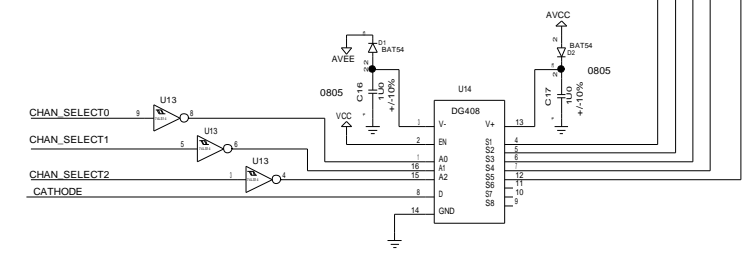
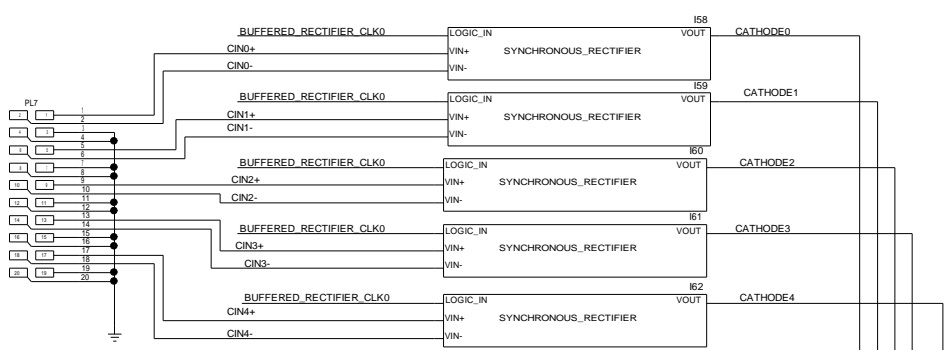

OUTPUT TO 16 CHANNEL ADC

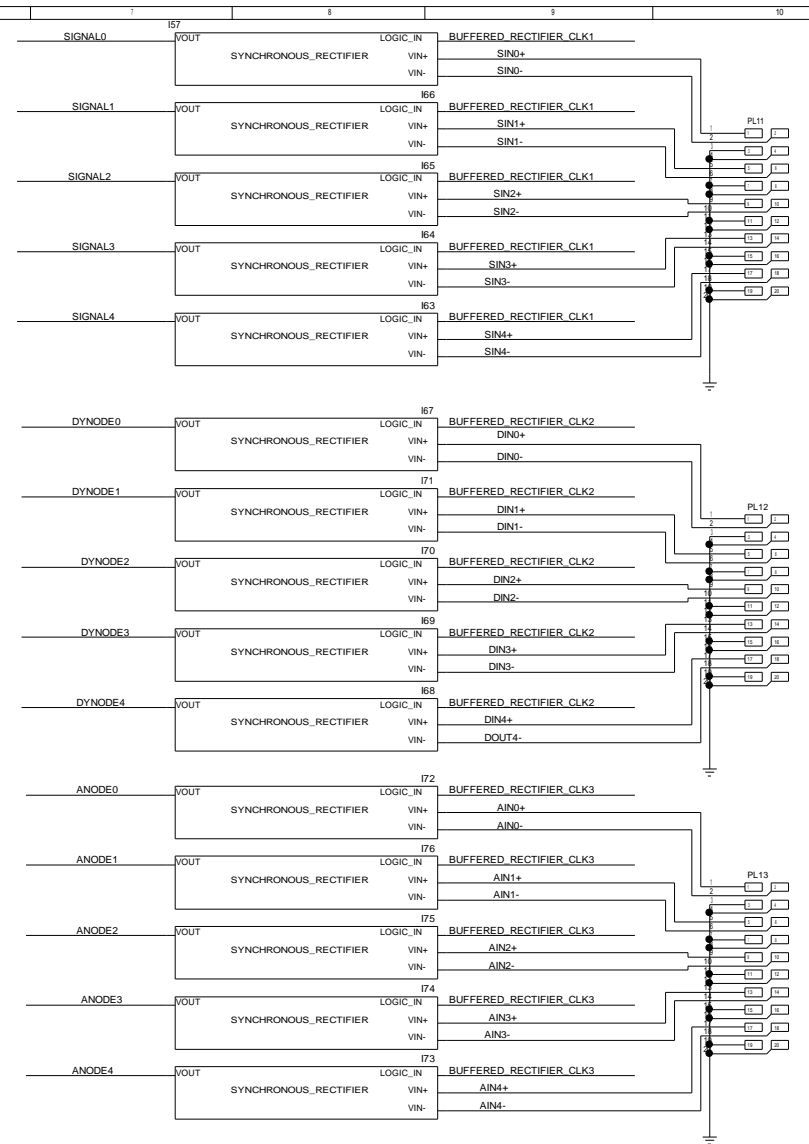
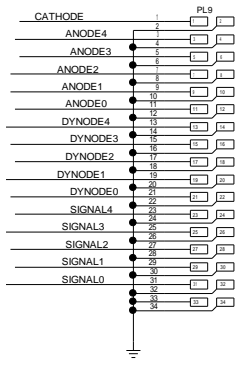
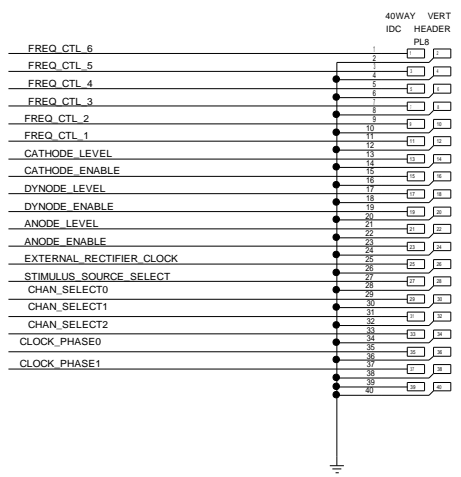

Fri Sep 8 10:53:35 2006		D.CUSSANS				
ISSUE	DATE	MOD NO.	DRN BY:	CHKD.	APPD.	STATUS
USED ON						UOB-HEP 20 06
UOB-HEP		H.H.WILLS PHYSICS LAB, TYNDALL AVE, BRISTOL, BS8 1TL.				
UNIVERSITY OF BRISTOL		HIGH ENERGY PHYSICS GROUP				
TITLE uob_hep_pc019a_lib						
MODULE: pc019a_readout						
BOARD WITH SPRING PROBES						
THAT PROBES HV FILTER BOARD						
A 2			MODULE PAGE: 3 OF 3			
			OVERALL PAGE: 3 OF 27			
TOTAL NO. OF SHEETS						

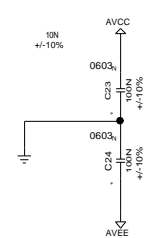
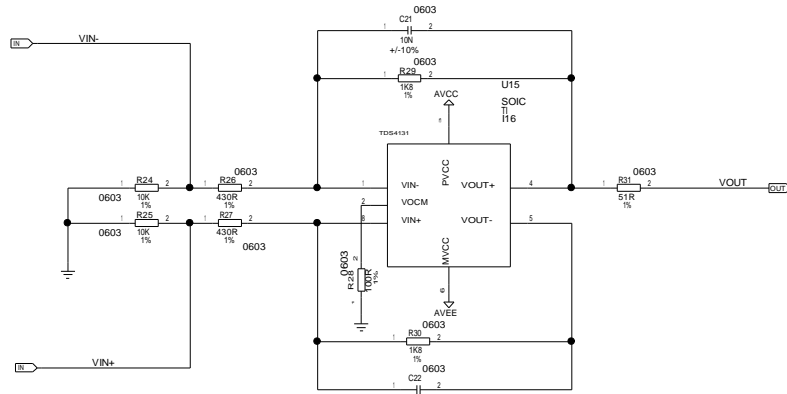

ISSUE	DATE	MOD. NO.	DRN. BY.	CHKD.	APPD.	STATUS
	Wed Aug 23	1225:11	2008			
USED ON						
UOB-HEP <small>UNIVERSITY OF BRISTOL HIGH ENERGY PHYSICS GROUP</small>						
H.H.WILLS PHYSICS LAB, TYNDALL AVE, BRISTOL, BS8 1TL.						
TITLE uob_hep_pc019a_lib						
MODULE: stimulus_driver						
TAKES TTL SIGNAL AND PROVIDES +/- 10V STIMULUS						
A 2		MODULE PAGE: 1 OF 1 OVERALL PAGE: 4 OF 27				
<small>TOTAL NO. OF SHEETS</small>						

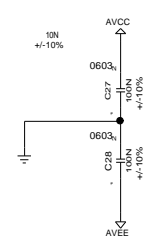
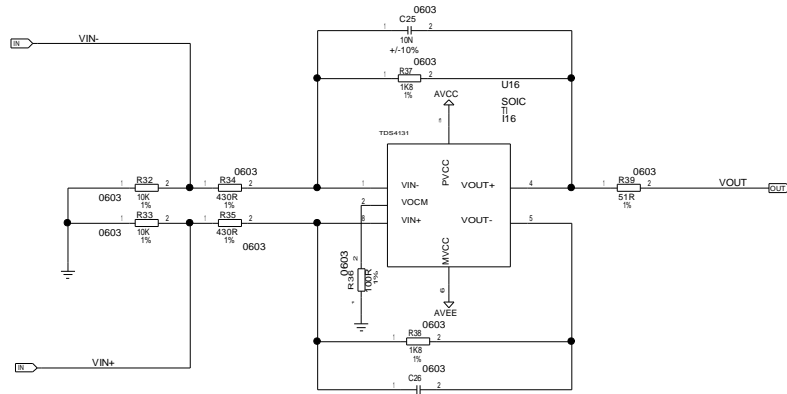

ISSUE	DATE	MOD. NO.	DRN. BY.	CHKD.	APPD.	STATUS
	Wed Aug 23		12:25:11	2008		
USED ON						
UOB-HEP 20						
UOB-HEP UNIVERSITY OF BRISTOL HIGH ENERGY PHYSICS GROUP						
H.H.WILLS PHYSICS LAB, TYNDALL AVE, BRISTOL, BS8 1TL.						
TITLE uob_hep_pc019a_lib						
MODULE: stimulus_driver						
TAKES TTL SIGNAL AND PROVIDES +/- 10V STIMULUS						
A 2		MODULE PAGE: 1 OF 1 OVERALL PAGE: 5 OF 27				
TOTAL NO. OF SHEETS						

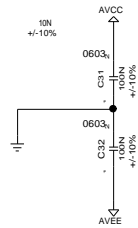
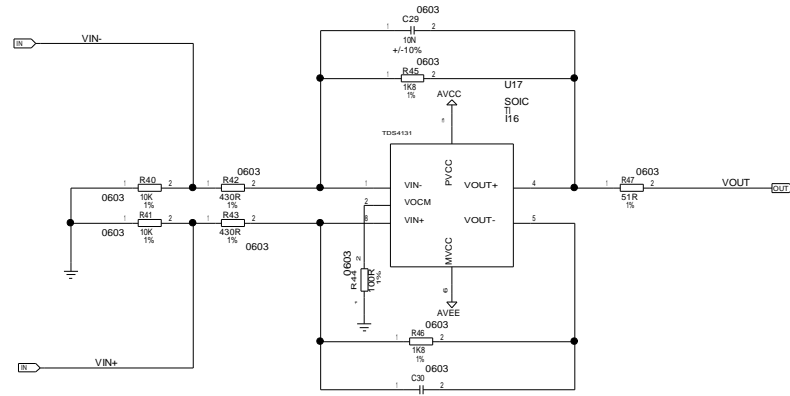

ISSUE	DATE	MOD. NO.	DRN. BY.	CHKD.	APPD.	STATUS
	Wed Aug 23	12:25:11	2008			
USED ON						
UOB-HEP 20						
UOB-HEP <small>UNIVERSITY OF BRISTOL HIGH ENERGY PHYSICS GROUP</small>						
H.H.WILLS PHYSICS LAB, TYNDALL AVE, BRISTOL, BS8 1TL.						
TITLE uob_hep_pc019a_lib						
MODULE: stimulus_driver						
TAKES TTL SIGNAL AND PROVIDES +/- 10V STIMULUS						
A 2		MODULE PAGE: 1 OF 1 OVERALL PAGE: 6 OF 27				
<small>TOTAL NO. OF SHEETS</small>						

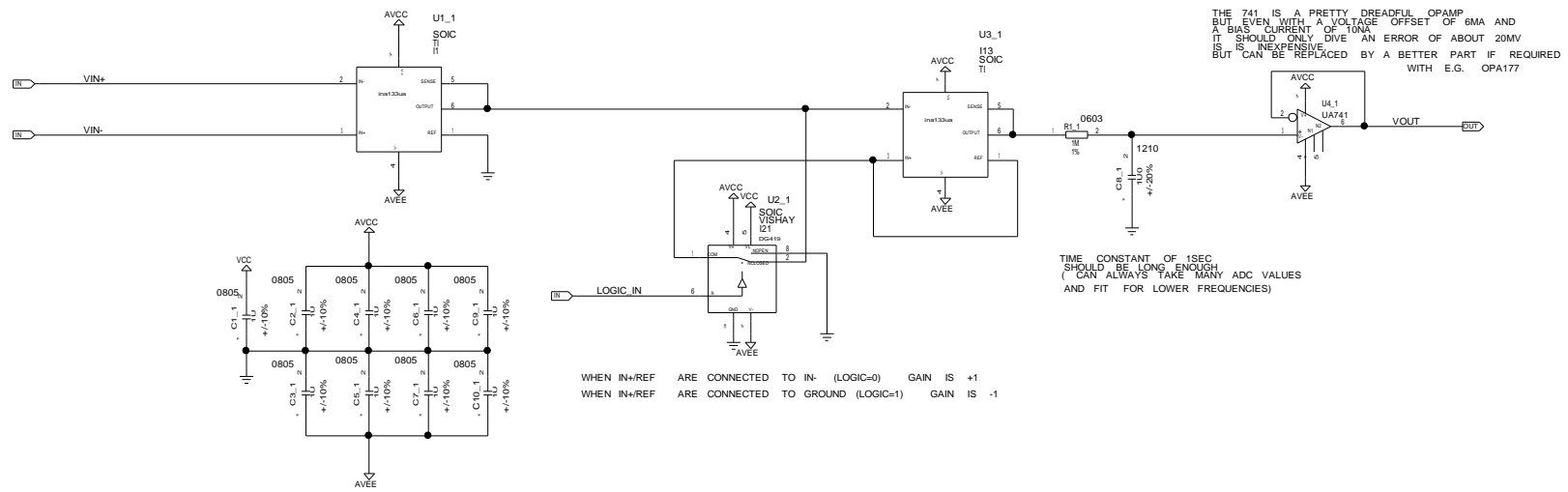

Thu Aug 17	16:04:19	2005						
ISSUE	DATE	MOD NO.	DRN BY.	CHKD.	APPD.	STATUS		
USED ON							UOB-HEP 20	
UOB-HEP		H.H.WILLS PHYSICS LAB, TYNDALL AVE, BRISTOL, BS8 1TL.						
TITLE		uob_hep_pc019a_lib						
MODULE:		synchronous_rectifier						
A 2		MODULE PAGE: 1 OF 1 OVERALL PAGE: 7 OF 27						
TOTAL NO. OF SHEETS								

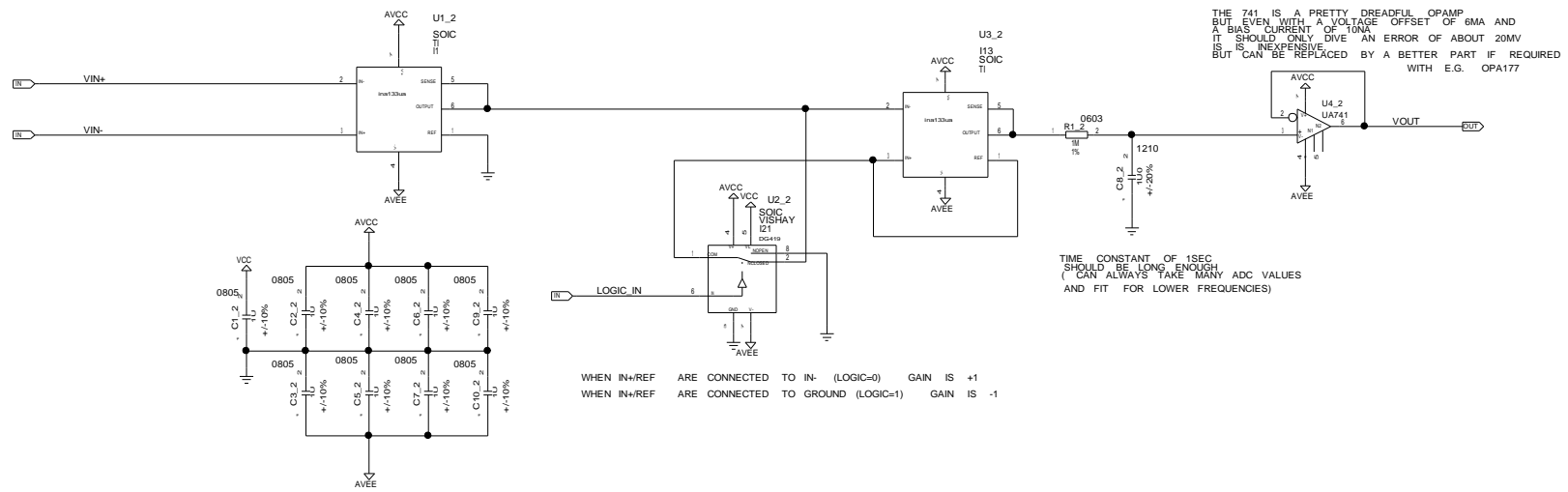

Thu Aug 17	16:04:19	2005					
ISSUE	DATE	MOD NO.	DRN BY:	CHKD.	APPD.	STATUS	
UOB-HEP 20							
UOB-HEP <small>UNIVERSITY OF BRISTOL HIGH ENERGY PHYSICS GROUP</small>							
H.H.WILLS PHYSICS LAB, TYNDALL AVE, BRISTOL, BS8 1TL.							
TITLE uob_hep_pc019a_lib							
MODULE: synchronous_rectifier							
A 2		MODULE PAGE: 1 OF 1 OVERALL PAGE: 8 OF 27					
<small>TOTAL NO. OF SHEETS</small>							

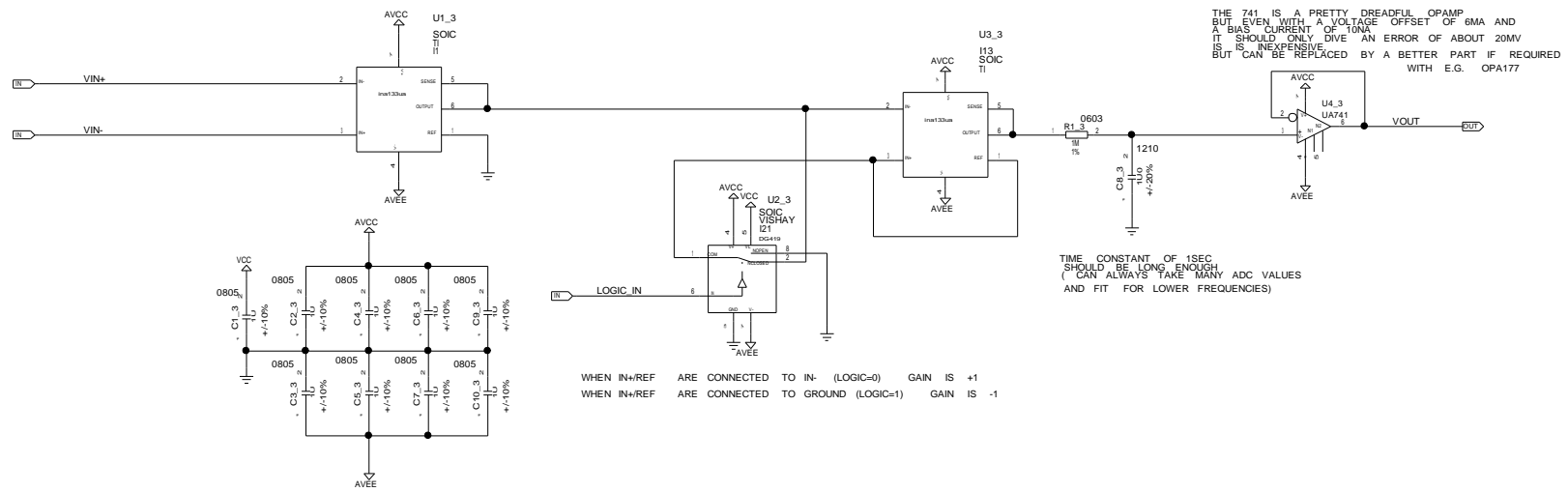

Thu	Aug	17	16:04:19	2005				
ISSUE	DATE	MOD NO.	DRN BY.	CHKD.	APPD.	STATUS		
USED ON						UOB-HEP 20		
UOB-HEP			H.H.WILLS PHYSICS LAB, TYNDALL AVE, BRISTOL, BS8 1TL.					
TITLE			uob_hep_pc019a_lib					
MODULE:			synchronous_rectifier					
A 2			MODULE PAGE: 1 OF 1 OVERALL PAGE: 9 OF 27					
TOTAL NO. OF SHEETS								

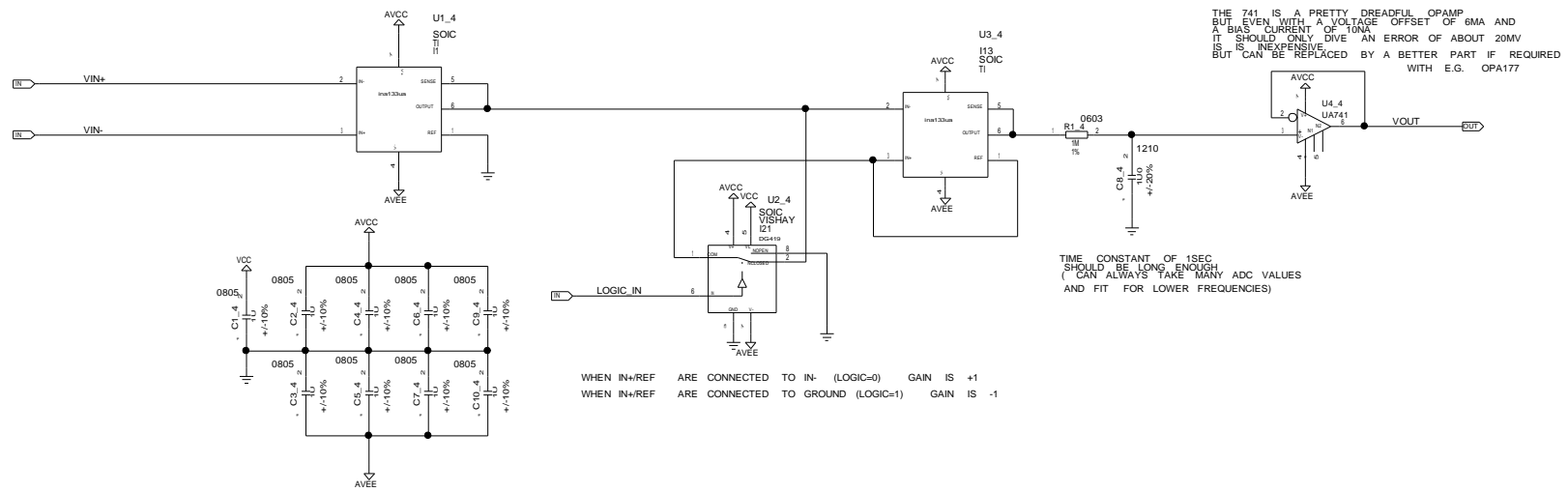

Thu Aug 17	16:04:19	2005					
ISSUE	DATE	MOD NO.	DRN BY.	CHKD.	APPD.	STATUS	
USED ON							UOB-HEP 20
UOB-HEP		H.H.WILLS PHYSICS LAB, TYNDALL AVE, BRISTOL, BS8 1TL.					
TITLE		uob_hep_pc019a_lib					
MODULE:		synchronous_rectifier					
A 2		MODULE PAGE: 1 OF 1		OVERALL PAGE: 10 OF 27		TOTAL NO. OF SHEETS	

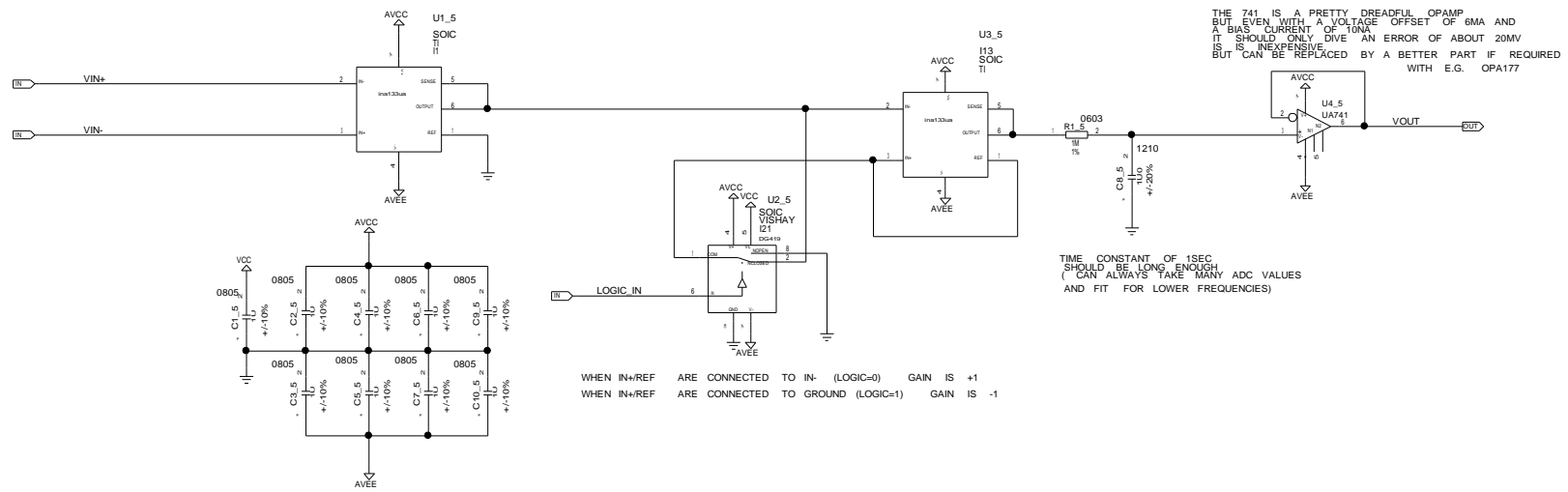

Thu Aug 17	16:04:19	2005					
ISSUE	DATE	MOD NO.	DRN BY.	CHKD.	APPD.	STATUS	
UOB-HEP 20							
UOB-HEP <small>UNIVERSITY OF BRISTOL HIGH ENERGY PHYSICS GROUP</small>							
H.H.WILLS PHYSICS LAB, TYNDALL AVE, BRISTOL, BS8 1TL.							
TITLE uob_hep_pc019a_lib							
MODULE: synchronous_rectifier							
A 2				MODULE PAGE: 1 OF 1 OVERALL PAGE: 11 OF 27			
<small>TOTAL NO. OF SHEETS</small>							

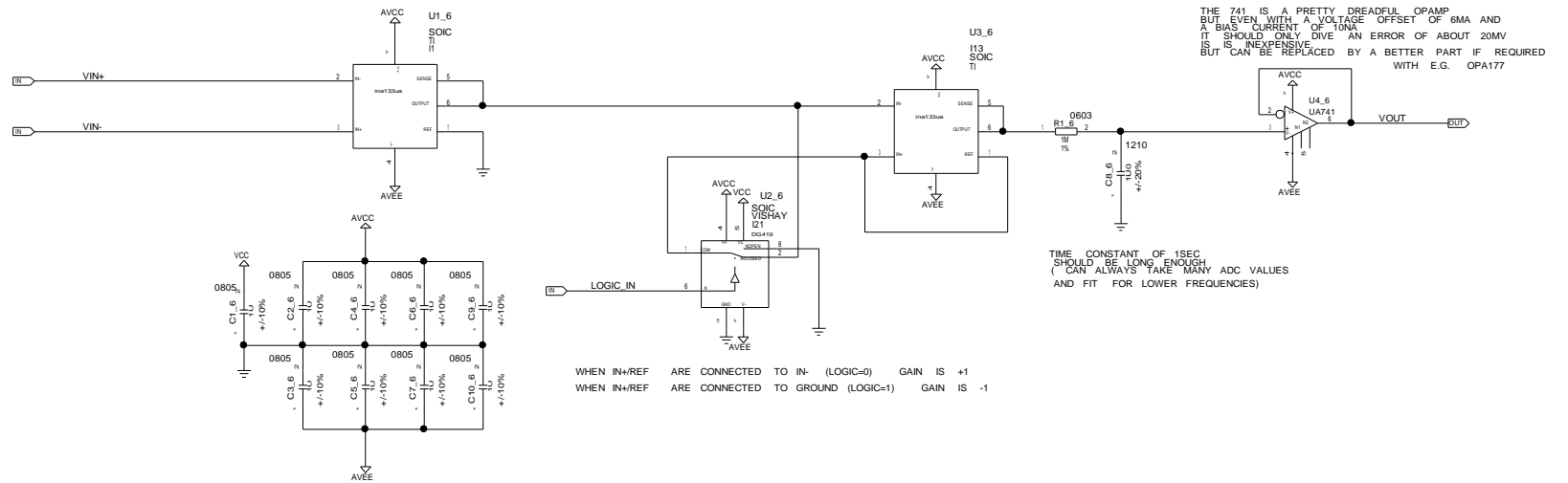

Thu Aug 17	16:04:19	2005					
ISSUE	DATE	MOD NO.	DRN BY.	CHKD.	APPD.	STATUS	
UOB-HEP 20							
UOB-HEP <small>UNIVERSITY OF BRISTOL HIGH ENERGY PHYSICS GROUP</small>							
H.H.WILLS PHYSICS LAB, TYNDALL AVE, BRISTOL, BS8 1TL.							
TITLE uob_hep_pc019a_lib							
MODULE: synchronous_rectifier							
A 2						MODULE PAGE: 1 OF 1 OVERALL PAGE: 12 OF 27	
<small>TOTAL NO. OF SHEETS</small>							

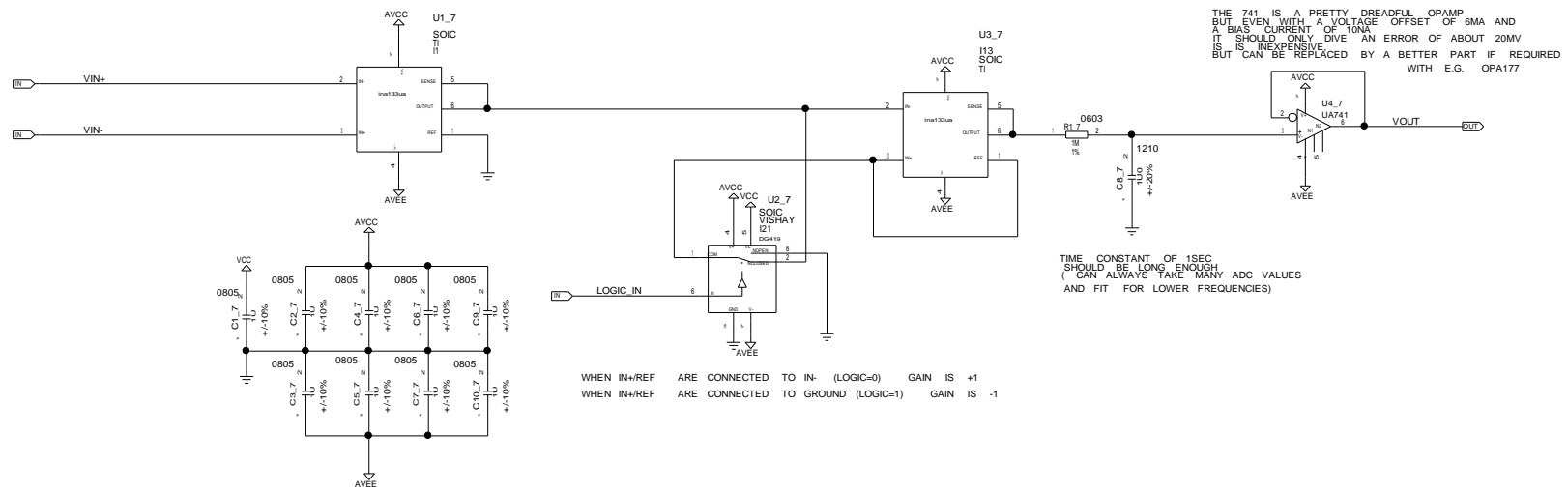

Thu Aug 17	16:04:19	2005					
ISSUE	DATE	MOD NO.	DRN BY:	CHKD.	APPD.	STATUS	
UOB-HEP 20							
UOB-HEP <small>UNIVERSITY OF BRISTOL HIGH ENERGY PHYSICS GROUP</small>							
H.H.WILLS PHYSICS LAB, TYNDALL AVE, BRISTOL, BS8 1TL.							
TITLE uob_hep_pc019a_lib MODULE: synchronous_rectifier							
A 2		MODULE PAGE: 1 OF 1 OVERALL PAGE: 13 OF 27					
<small>TOTAL NO. OF SHEETS</small>							

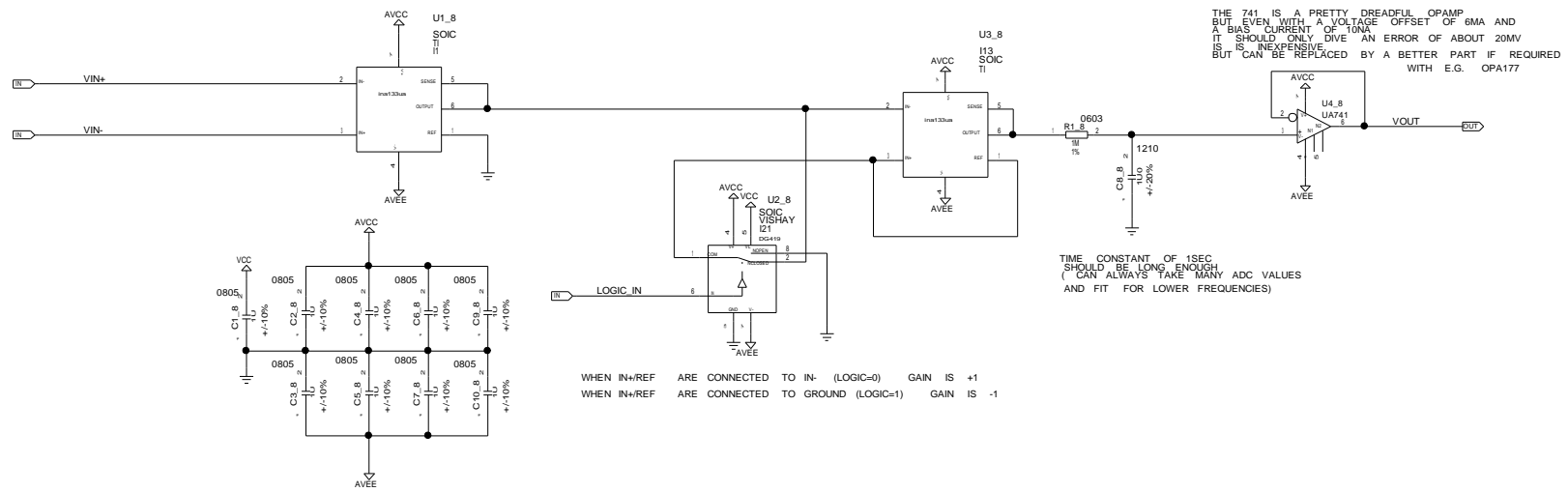

Thu Aug 17	16:04:19	2005							
ISSUE	DATE	MOD NO.	DRN BY.	CHKD.	APPD.	STATUS			
USED ON							UOB-HEP 20		
UOB-HEP		UNIVERSITY OF BRISTOL HIGH ENERGY PHYSICS GROUP						H.H.WILLS PHYSICS LAB, TYNDALL AVE, BRISTOL, BS8 1TL.	
TITLE		uob_hep_pc019a_lib						MODULE: synchronous_rectifier	
A 2		MODULE PAGE: 1 OF 1						OVERALL PAGE: 14 OF 27	
TOTAL NO. OF SHEETS									

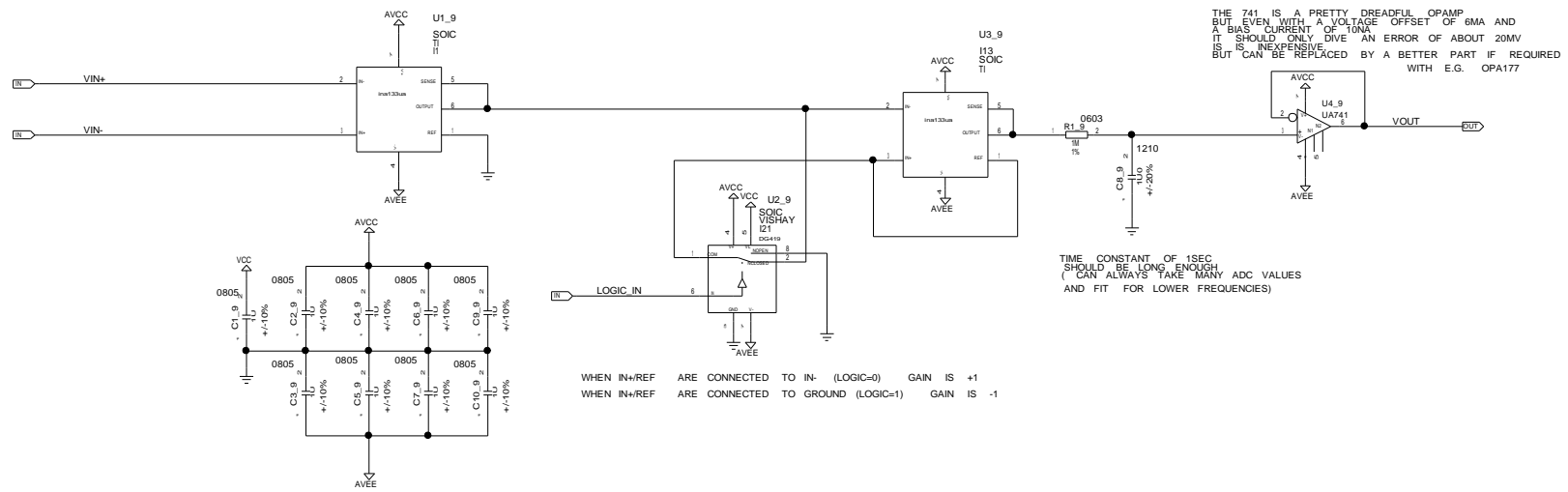

Thu Aug 17	16:04:19	2005							
ISSUE	DATE	MOD NO.	DRN BY.	CHKD.	APPD.	STATUS			
USED ON							UOB-HEP 20		
UOB-HEP		UNIVERSITY OF BRISTOL HIGH ENERGY PHYSICS GROUP						H.H.WILLS PHYSICS LAB, TYNDALL AVE, BRISTOL, BS8 1TL.	
TITLE		uob_hep_pc019a_lib						MODULE: synchronous_rectifier	
A 2		MODULE PAGE: 1 OF 1						OVERALL PAGE: 15 OF 27	
TOTAL NO. OF SHEETS									

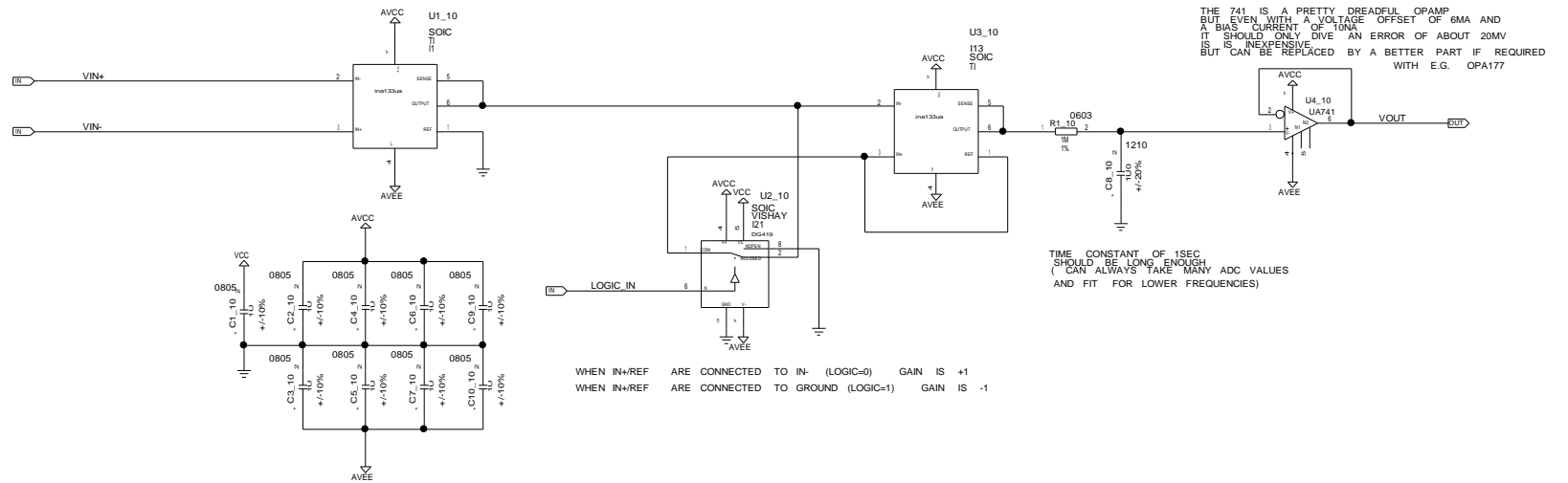

Thu Aug 17	16:04:19	2005							
ISSUE	DATE	MOD NO.	DRN BY.	CHKD.	APPD.	STATUS			
USED ON							© UOB-HEP 20		
UOB-HEP		UNIVERSITY OF BRISTOL HIGH ENERGY PHYSICS GROUP						H.H.WILLS PHYSICS LAB, TYNDALL AVE, BRISTOL, BS8 1TL.	
TITLE		uob_hep_pc019a_lib							
MODULE:		synchronous_rectifier							
A 2		MODULE PAGE: 1 OF 1						OVERALL PAGE: 16 OF 27	
TOTAL NO. OF SHEETS									

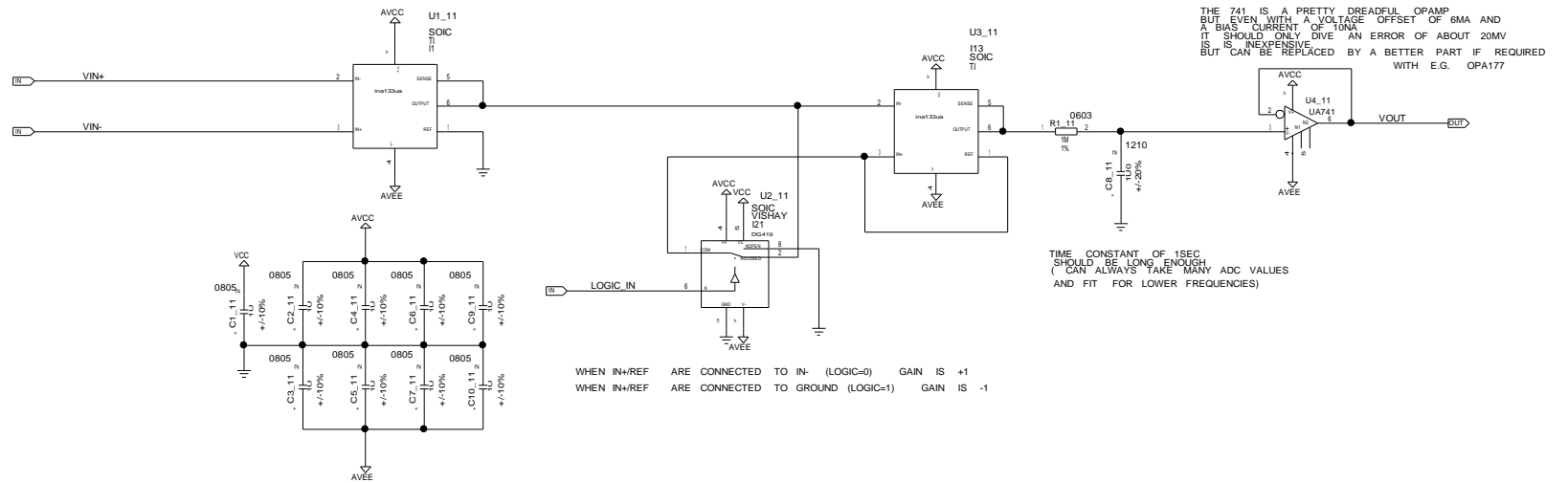

Thu Aug 17	16:04:19	2005					
ISSUE	DATE	MOD NO.	DRN BY.	CHKD.	APPD.	STATUS	
USED ON							UOB-HEP 20
UOB-HEP		UNIVERSITY OF BRISTOL HIGH ENERGY PHYSICS GROUP					
H.H.WILLS		PHYSICS LAB, TYNDALL AVE, BRISTOL, BS8 1TL.					
TITLE		uob_hep_pc019a_lib					
MODULE:		synchronous_rectifier					
A 2		MODULE PAGE: 1 OF 1 OVERALL PAGE: 17 OF 27					
TOTAL NO. OF SHEETS							

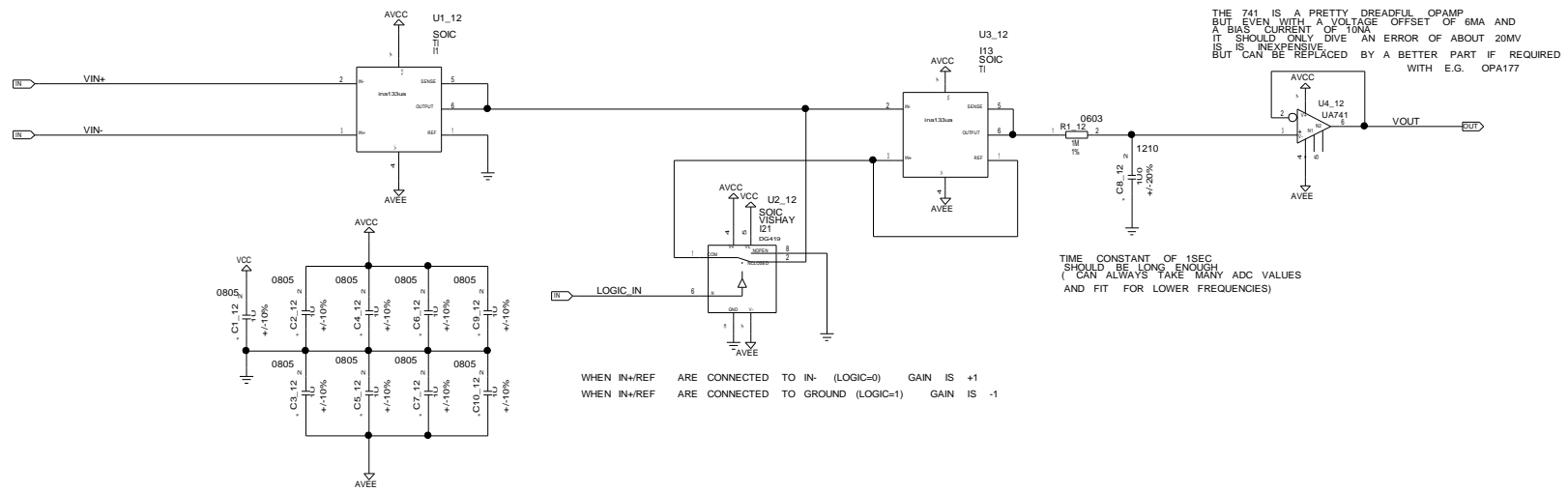

Thu Aug 17	16:04:19	2005							
ISSUE	DATE	MOD NO.	DRN BY.	CHKD.	APPD.	STATUS			
USED ON							UOB-HEP 20		
UOB-HEP		UNIVERSITY OF BRISTOL HIGH ENERGY PHYSICS GROUP						H.H.WILLS PHYSICS LAB, TYNDALL AVE, BRISTOL, BS8 1TL.	
TITLE		uob_hep_pc019a_lib						MODULE: synchronous_rectifier	
A 2		MODULE PAGE: 1 OF 1 OVERALL PAGE: 18 OF 27						TOTAL NO. OF SHEETS	

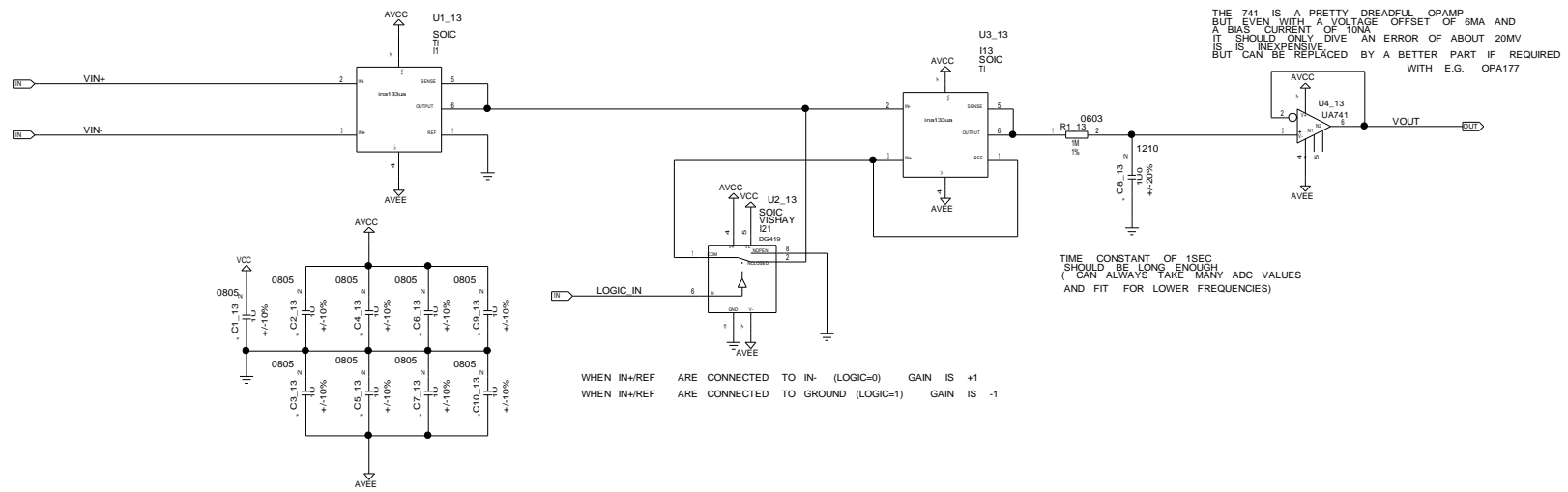

Thu Aug 17	16:04:19	2005					
ISSUE	DATE	MOD NO.	DRN BY.	CHKD.	APPD.	STATUS	
USED ON							UOB-HEP 20
UOB-HEP		H.H.WILLS PHYSICS LAB, TYNDALL AVE, BRISTOL, BS8 1TL.					
TITLE		uob_hep_pc019a_lib					
MODULE:		synchronous_rectifier					
A 2		MODULE PAGE: 1 OF 1					OVERALL PAGE: 19 OF 27
TOTAL NO. OF SHEETS							

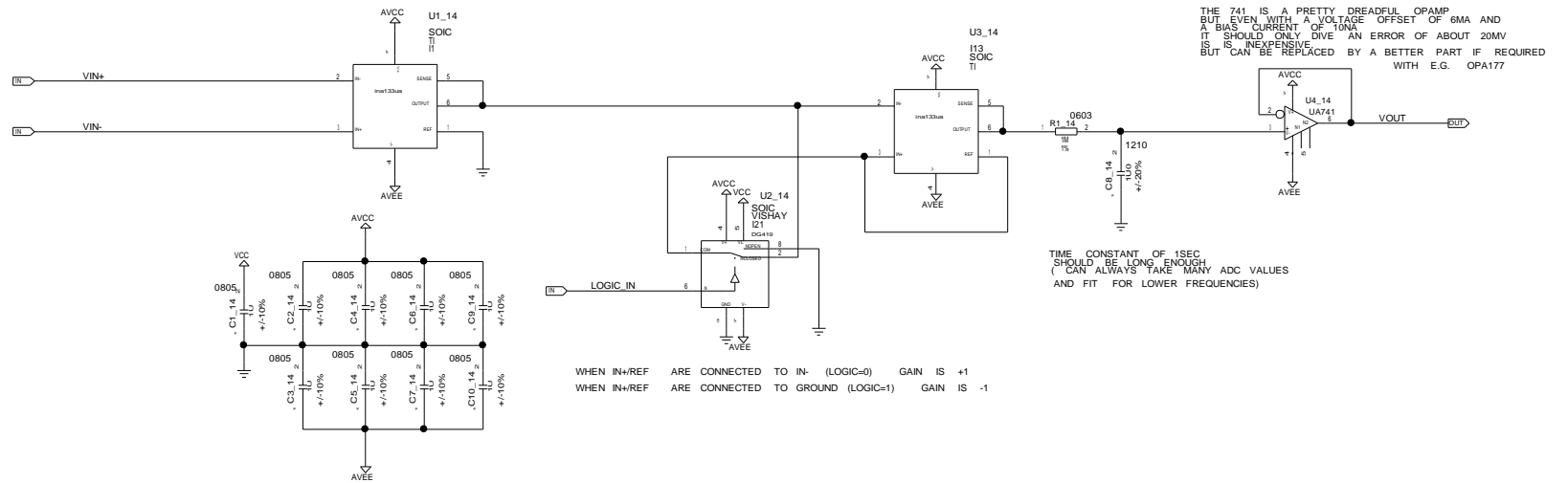

Thu Aug 17	16:04:19	2005							
ISSUE	DATE	MOD NO.	DRN BY.	CHKD.	APPD.	STATUS			
USED ON							UOB-HEP 20		
UOB-HEP		UNIVERSITY OF BRISTOL HIGH ENERGY PHYSICS GROUP						H.H.WILLS PHYSICS LAB, TYNDALL AVE, BRISTOL, BS8 1TL.	
TITLE		uob_hep_pc019a_lib							
MODULE:		synchronous_rectifier							
A 2		MODULE PAGE: 1 OF 1						OVERALL PAGE: 20 OF 27	
TOTAL NO. OF SHEETS									

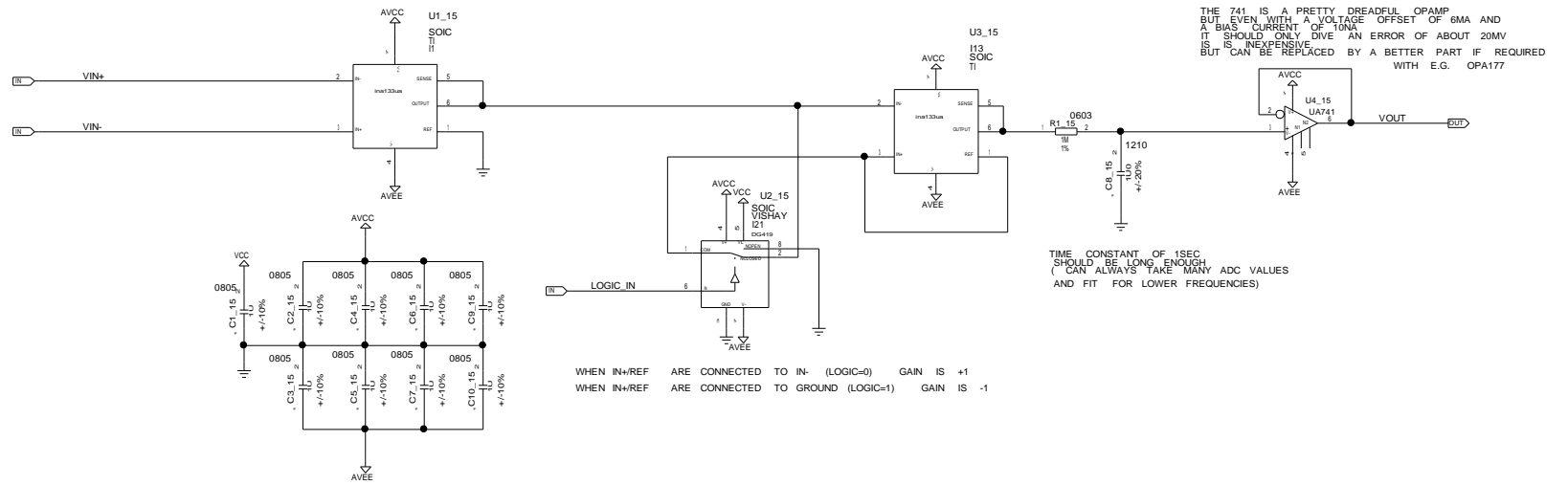

Thu Aug 17	16:04:19	2005						
ISSUE	DATE	MOD NO.	DRN BY.	CHKD.	APPD.	STATUS		
USED ON							UOB-HEP 20	
UOB-HEP		H.H.WILLS PHYSICS LAB, TYNDALL AVE, BRISTOL, BS8 1TL.						
TITLE		uob_hep_pc019a_lib						
MODULE:		synchronous_rectifier						
A 2		MODULE PAGE: 1 OF 1						
		OVERALL PAGE: 21 OF 27						
TOTAL NO. OF SHEETS								

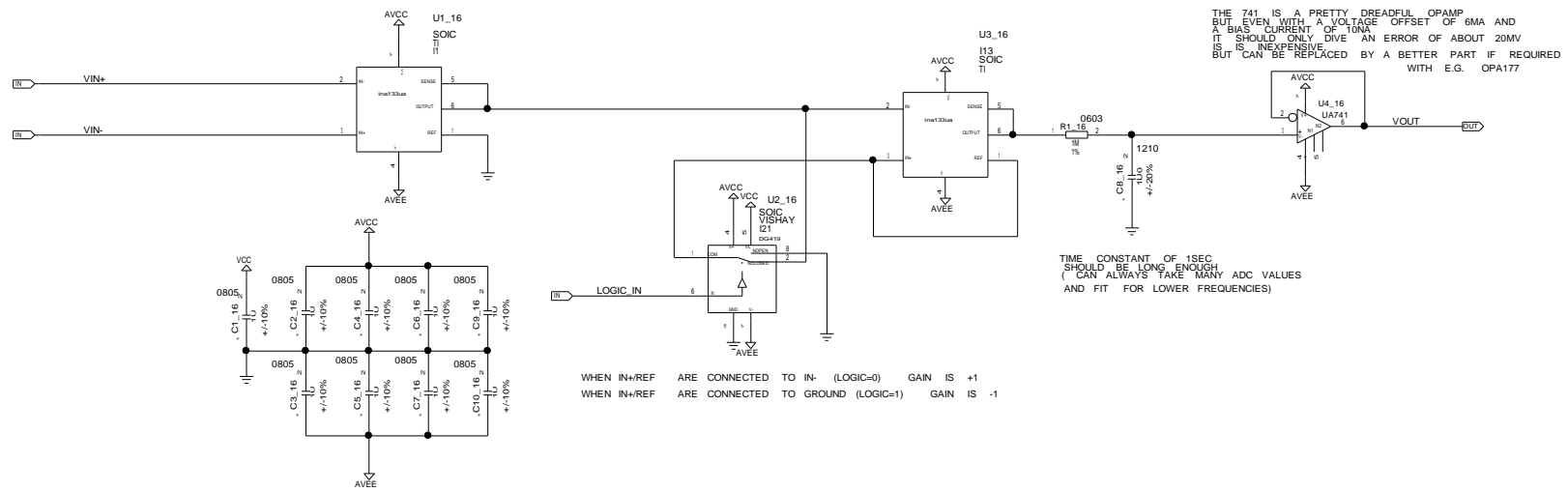

Thu Aug 17	16:04:19	2005					
ISSUE	DATE	MOD NO.	DRN BY.	CHKD.	APPD.	STATUS	
USED ON							UOB-HEP 20
UOB-HEP <small>UNIVERSITY OF BRISTOL HIGH ENERGY PHYSICS GROUP</small>							
H.H.WILLS PHYSICS LAB, TYNDALL AVE, BRISTOL, BS8 1TL.							
TITLE uob_hep_pc019a_lib MODULE: synchronous_rectifier							
A 2				MODULE PAGE: 1 OF 1 OVERALL PAGE: 22 OF 27			
<small>TOTAL NO. OF SHEETS</small>							

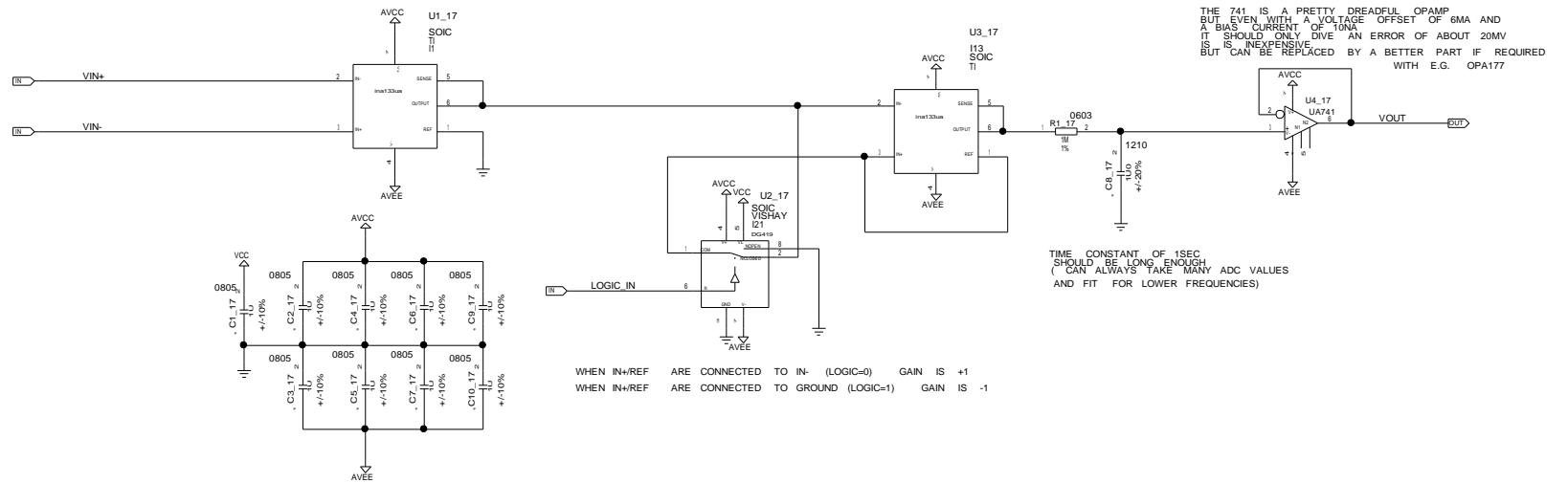

Thu Aug 17	16:04:19	2005					
ISSUE	DATE	MOD NO.	DRN BY.	CHKD.	APPD.	STATUS	
USED ON							UOB-HEP 20
UOB-HEP		H.H.WILLS PHYSICS LAB, TYNDALL AVE, BRISTOL, BS8 1TL.					
TITLE		uob_hep_pc019a_lib					
MODULE:		synchronous_rectifier					
A 2		MODULE PAGE: 1 OF 1					OVERALL PAGE: 23 OF 27
TOTAL NO. OF SHEETS							

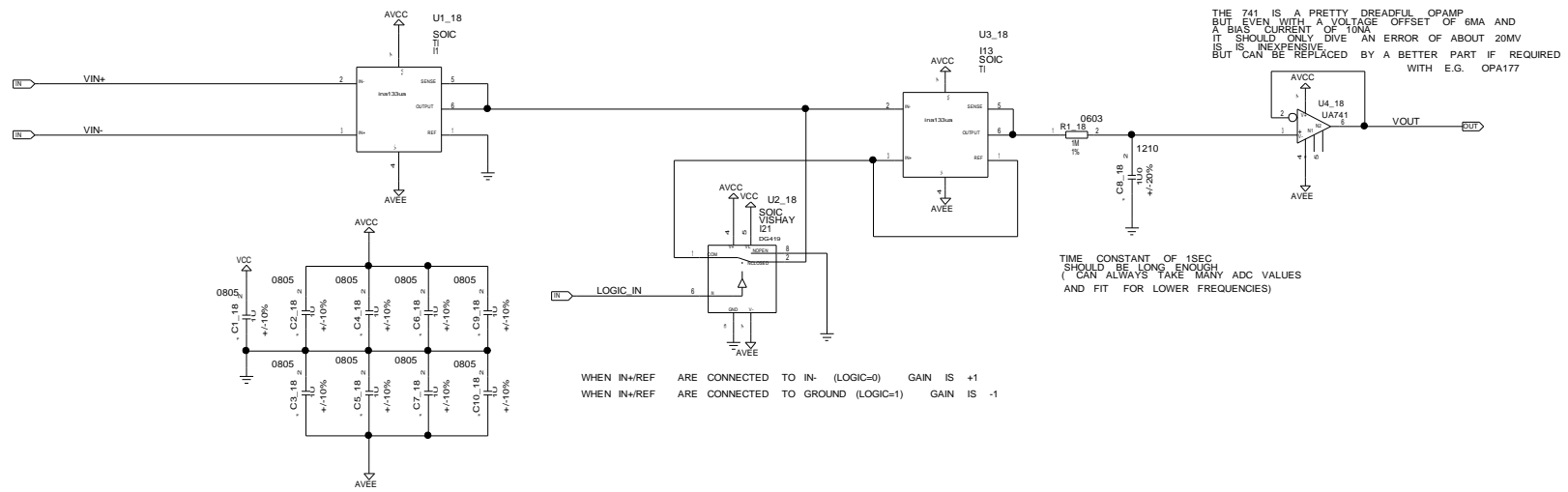

Thu Aug 17	16:04:19	2005					
ISSUE	DATE	MOD NO.	DRN BY.	CHKD.	APPD.	STATUS	
USED ON							UOB-HEP 20
UOB-HEP		H.H.WILLS PHYSICS LAB, TYNDALL AVE, BRISTOL, BS8 1TL.					
TITLE		uob_hep_pc019a_lib					
MODULE:		synchronous_rectifier					
A 2		MODULE PAGE: 1 OF 1					OVERALL PAGE: 24 OF 27
TOTAL NO. OF SHEETS							

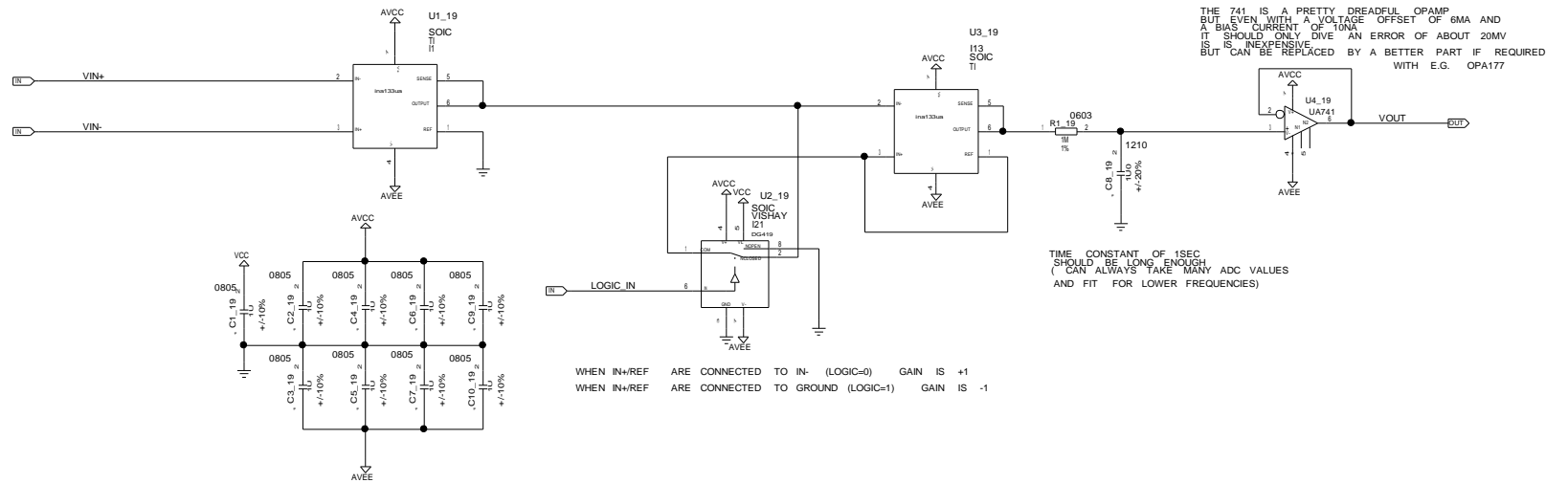

Thu Aug 17	16:04:19	2005							
ISSUE	DATE	MOD NO.	DRN BY.	CHKD.	APPD.	STATUS			
USED ON							UOB-HEP 20		
UOB-HEP		UNIVERSITY OF BRISTOL HIGH ENERGY PHYSICS GROUP						H.H.WILLS PHYSICS LAB, TYNDALL AVE, BRISTOL, BS8 1TL.	
TITLE		uob_hep_pc019a_lib						MODULE: synchronous_rectifier	
A 2		MODULE PAGE: 1 OF 1 OVERALL PAGE: 25 OF 27						TOTAL NO. OF SHEETS	

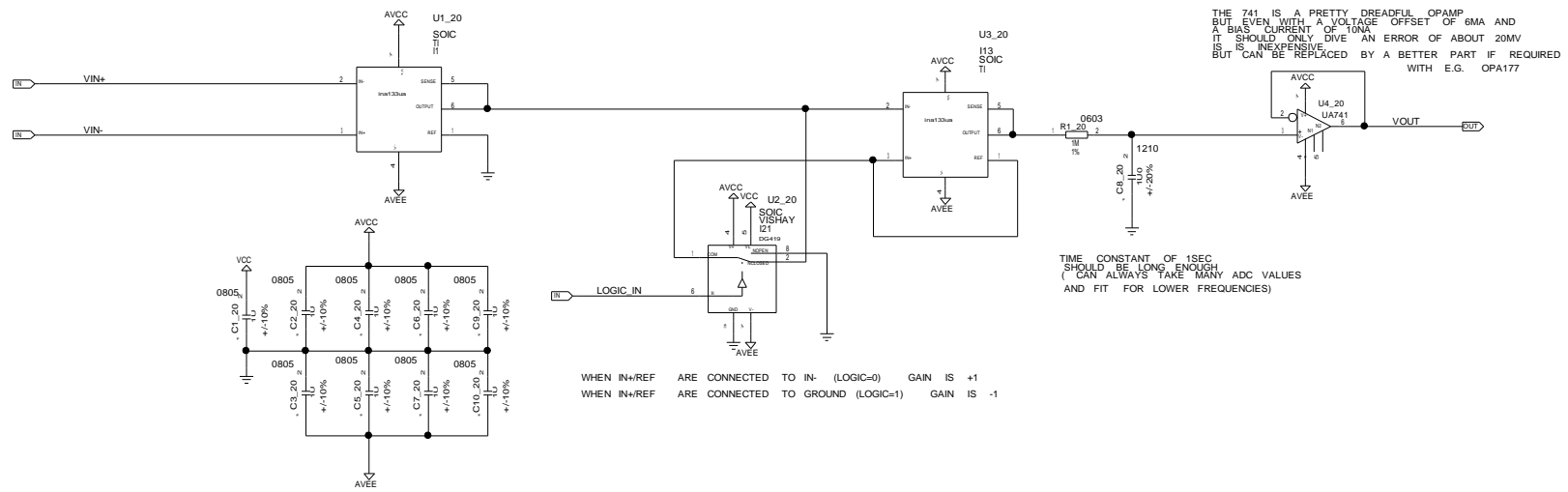

Thu Aug 17	16:04:19	2005					
ISSUE	DATE	MOD NO.	DRN BY.	CHKD.	APPD.	STATUS	
USED ON							UOB-HEP 20
UOB-HEP		H.H.WILLS PHYSICS LAB, TYNDALL AVE, BRISTOL, BS8 1TL.					
TITLE		uob_hep_pc019a_lib					
MODULE:		synchronous_rectifier					
A 2		MODULE PAGE: 1 OF 1					OVERALL PAGE: 26 OF 27
TOTAL NO. OF SHEETS							

