

N° ORIG.	SIGN AND DATE	CHANGE N°	COPY N°	SIGN AND DATE

NOTE N°	FIRST APPLICATION
	7966-01-00-00

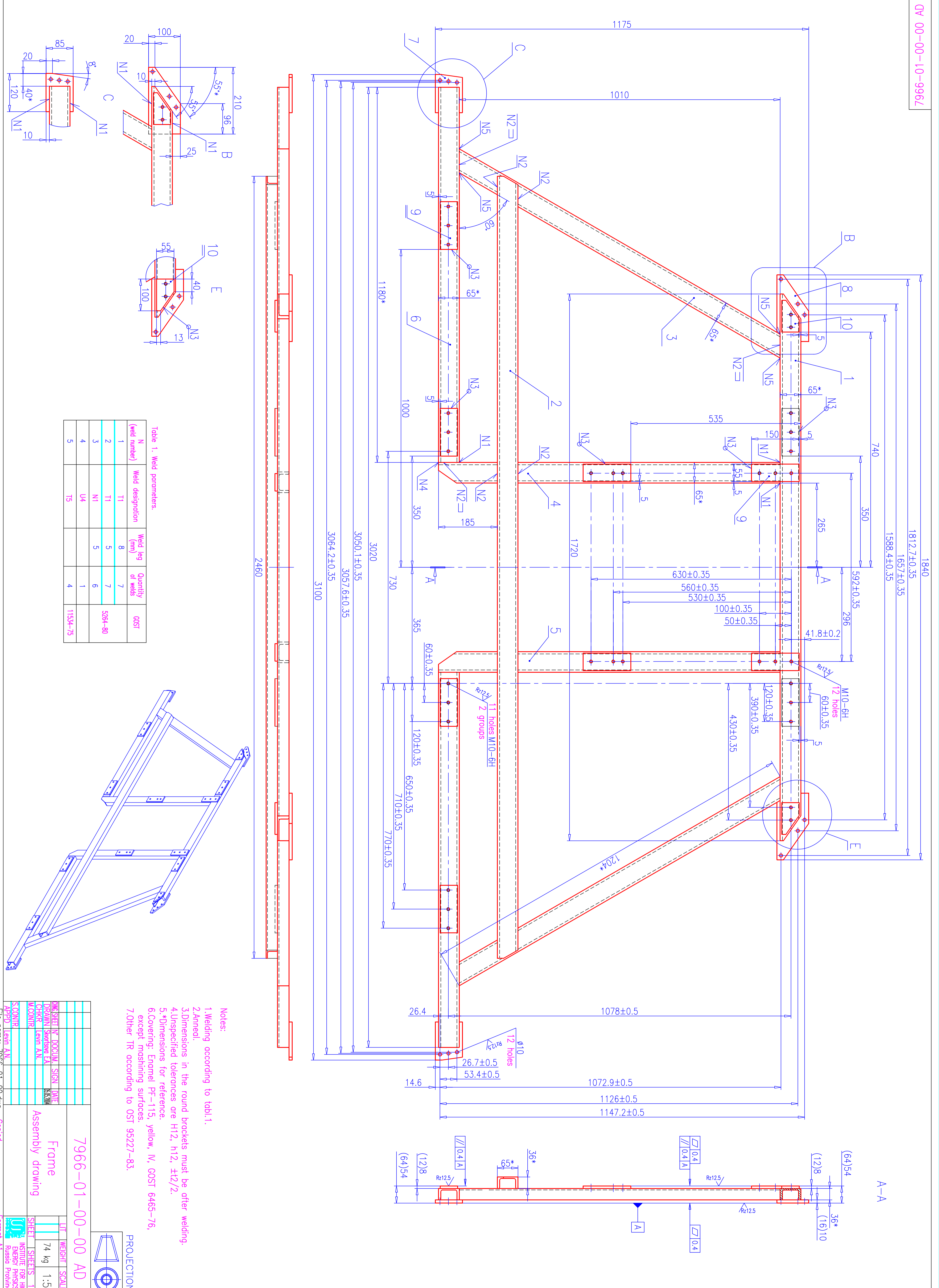

- Notes:
1. Welding according to tabl.1.
 2. Anneal.
 3. Dimensions in the round brackets must be after welding.
 4. Unspecified tolerances are H12, h12, ±12/2.
 5. *Dimensions for reference.
 6. Covering: Enamel Pf-115, yellow, W, GOST 6465-76, except mashing surfaces.
 7. Other TR according to OST 95227-83.

Table 1. Weld parameters.

N (weld number)	Weld designation	Weld leg (mm)	Quantity of welds	GOST
1	T1	8	7	
2	T1	5	7	5284-80
3	N1	5	6	
4	U4		1	
5	T5		4	11534-75

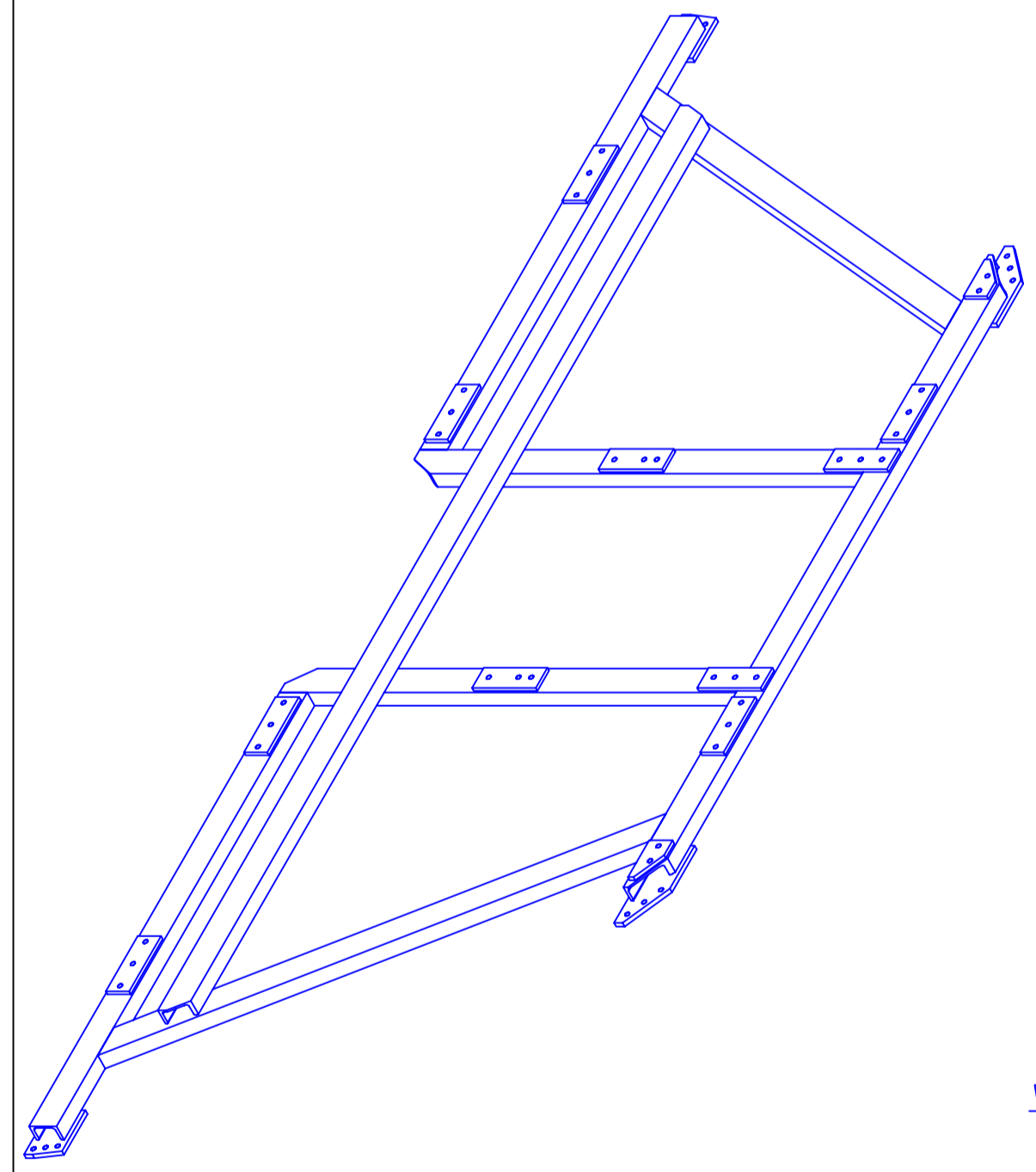

DESIGNER	DATE	7966-01-00-00 AD
DRAWN	SIGN	Assembly drawing
CHECKED	DATE	
APPROVED	DATE	
FILE NAME	7966-01-00.dwg	Copied

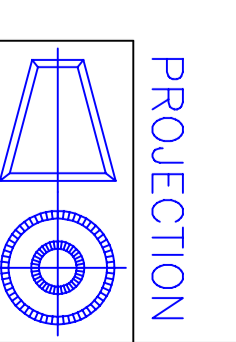

PROJECTION

LIT WEIGHT SCALE

74 kg 1:5

SHEET SHEETS 1

INSTITUTE FOR HIGH ENERGY PHYSICS

Russia Protvino

Formot AI