

A Measurement of the Temperature Stability of Vacuum Phototriodes for the CMS ECAL

D. Andelin¹, M. Arenton¹, M. Balazs¹, S. Conetti¹, B. Cox¹, R. Hirosky¹,
R. Imlay¹, A. Ledovskoy¹, A. Lobb¹, D.G. Phillips II^{1,*}, M. Ronquest¹

¹*Department of Physics, University of Virginia, Charlottesville, Virginia 22904-4714, USA*

I. Introduction

This note describes a measurement of the temperature dependence of a single channel VPT (Vacuum Phototriode) system as designed for use in the CMS ECAL. The primary interest is the temperature dependence near the ECAL operating temperature of $(18 \pm 0.1)^\circ\text{C}$. Due to cooling limitations, measurements in this study were limited to the range 24°C - 38°C and we therefore extrapolate our final result to the EE operating temperature. We find the temperature dependence of the VPT/amplifier system to be approximately $(-0.178^{+0.0155}_{-0.022})\%$ per $^\circ\text{C}$ at EE operating temperatures.

II. Apparatus

The VPTs used in this study are manufactured by Research Institute Electron in St. Petersburg, Russia, and are identical to those manufactured for the CMS ECAL endcap (EE). The mean quantum efficiency of the VPTs has been measured to be 22% at 430 nm, with a standard deviation of 3%, and a mean gain of 10.2 at 0 Tesla, with a standard deviation of 1.8 [1]. Our test apparatus consisted of a 5 mm diameter superbright blue LED, a 1 mm diameter optical fiber to deliver light to the VPT, and a single channel VPT/amplifier system (see Fig. 1). The LED used was produced by Super Bright LEDs, Inc. [2]. It produces a mean spectral wavelength of 467 nm with an intensity of 5500 mcd at a forward current of 20 mA and a forward voltage of 3.5 V. Light is emitted with a viewing angle of 15 degrees. A 1 mm diameter cylindrical hole was drilled 2 mm above the junction of the LED to allow for insertion of the fiber. The fiber was attached to the LED using Dow Corning RTV 3145, which is the same adhesive used to attach the VPTs to the PbWO_4 crystals in the EE [3]. The optical fiber was 70 cm long and the free end was placed in contact (but not glued) to the face of the VPT photocathode. This is a potential source of instability in the system, because the light transfer to the VPT is

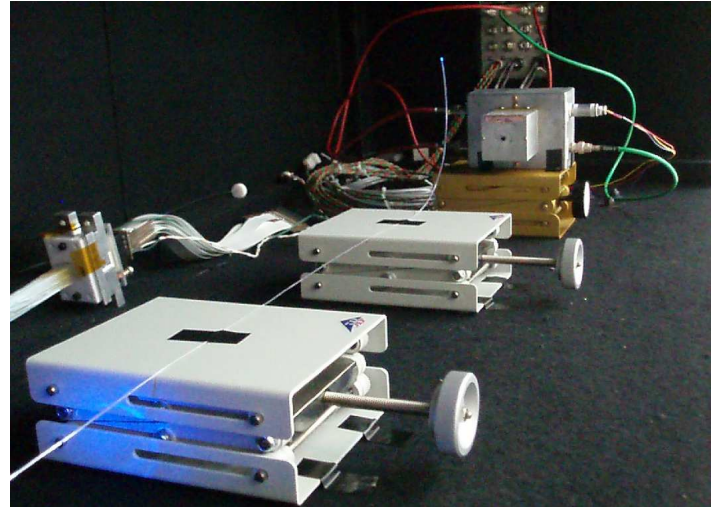

Fig 1: Light was transferred from the LED (foreground; not shown) to the single channel VPT device (background) via an optical fiber. The amplifier is located directly behind the VPT in the same encasing. For clarity, the end of the optical fiber is shown in the foreground.

observed to be highly dependent on the quality of its optical contact with the fiber. The entire setup was situated inside a large light-proof enclosure (a Faraday cage) with dimensions (60 x 60 x 150) cm.

The light-proof box was divided into three regions by inserting two 5 cm thick sheets of Styrofoam that were 36 cm apart. The LED was located in the left region (foreground of Fig. 1), the VPT with its amplifier in the right region. The fiber was threaded through small holes in the Styrofoam. One temperature probe was placed next to the LED and another above the VPT's encasing. The temperature probes were produced by Novalynx Corporation and are listed as Model 225-050Y. The probes are cylindrical in shape with a radius of 0.6 cm and a length of 6.9 cm and measure temperature to within an accuracy of $\pm 0.5^\circ\text{C}$. Two 15 W heaters consisting of several resistors were placed near the VPT and LED to vary their temperatures. Both heaters were placed approximately 8 cm away from the VPT to create a more uniform temperature profile. Four 2 cm thick Styrofoam pieces were used to create an enclosure around the VPT

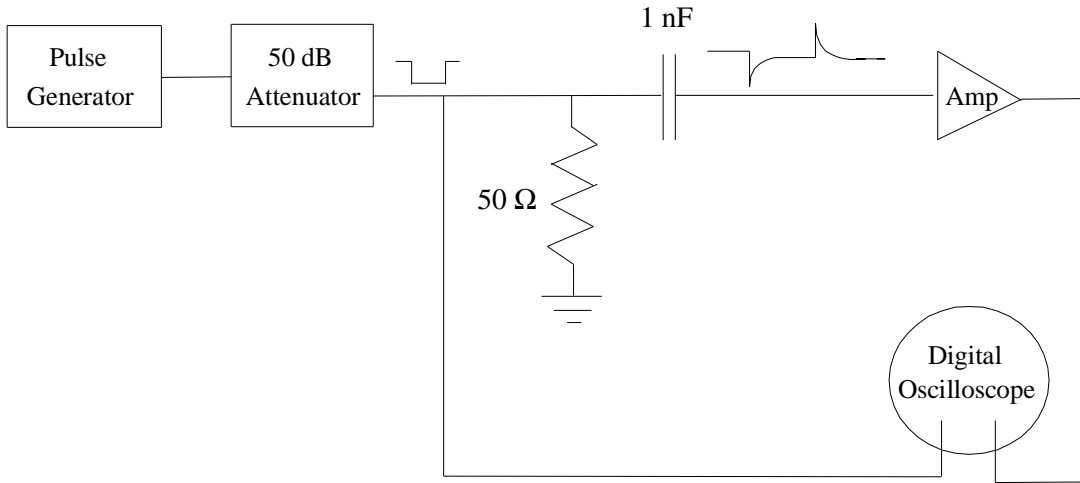

Fig 2: Schematic for Amplifier Charge Injection

and heater. In the enclosure, both the VPT and amplifier are heated together. The heaters increased the temperature by approximately $15\text{ }^{\circ}\text{C}$ over a three hour period before reaching equilibrium. Since the different sections of the box were thermally well isolated, no increase was observed in the temperature of the LED due to the heater when the VPT temperature was varied.

For measurements of the temperature dependence of the LED the heaters were placed in a similar styrofoam enclosure containing the LED; in this case, the heaters were placed 4 cm away from the LED.

The VPT was operated with the photocathode grounded. The anode was set at $V_A = 1000\text{ V}$, while the dynode was operated 200 V lower ($V_D = 800\text{ V}$) to maximize the collection of secondary electrons from the dynode [4]. The signal output from the VPT amplifier went to a digital oscilloscope, which was used to read the output pulse width, frequency, and amplitude.

III. Amplifier Temperature Dependence

The temperature dependence of the amplifier was measured using charge injection in place of a pulse from the VPT. The procedure outlined below is described more thoroughly in Ref.[5]. A square pulse with a width of $1\text{ }\mu\text{s}$ and an amplitude of 1.0 V (through 50Ω impedance) was attenuated by 50 dB and then capacitively coupled to the amplifier's test input using a 1nF capacitor as shown in Fig. 2. The pulses were delivered at a frequency of 11 kHz. The digital oscilloscope calculated a pulse height based on the average of 512 acquisitions. Five sets of measurements were made and the data are shown in Fig. 3. Three sets of measurements tracked the gain of the

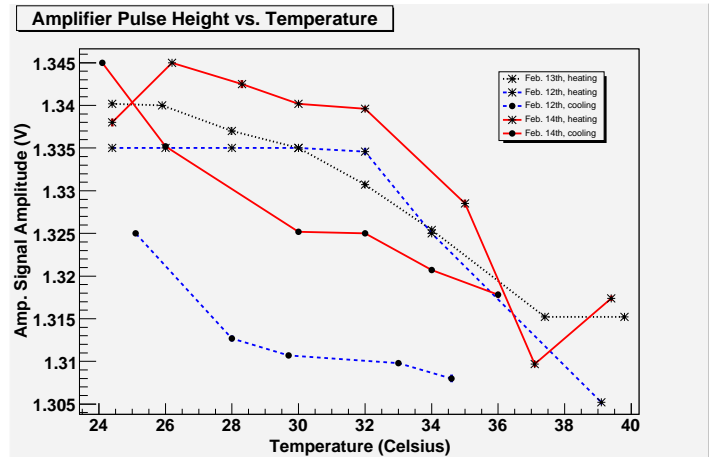

Fig 3: Amplifier response vs. temperature

amplifier while the temperature was increased, while the other two sets monitor the gain during recovery to the ambient temperature. There is a noticeable “hysteresis effect” in the data. By hysteresis, we refer to the observation from the data that the heating and cooling of the amplifier does not follow the same thermal curves. We attribute this phenomenon to a lag between the measured temperature and the actual temperature of the electronics, because the temperature probe was located outside the metal enclosures for the VPT and amplifier. Thus we expect the measured temperature during (cooling) heating to (under)overestimate the temperatures of the electronics. To compensate for this effect, we interpolate (horizontally) between the heating and cooling curves to estimate the nominal temperature of the electronics at each signal amplitude. We set the nominal temperature to be the midpoint between the two extreme values and estimate the uncertainty according to a uniform distribution, ($temp.\ range/\sqrt{12}$). The uncertainty in the

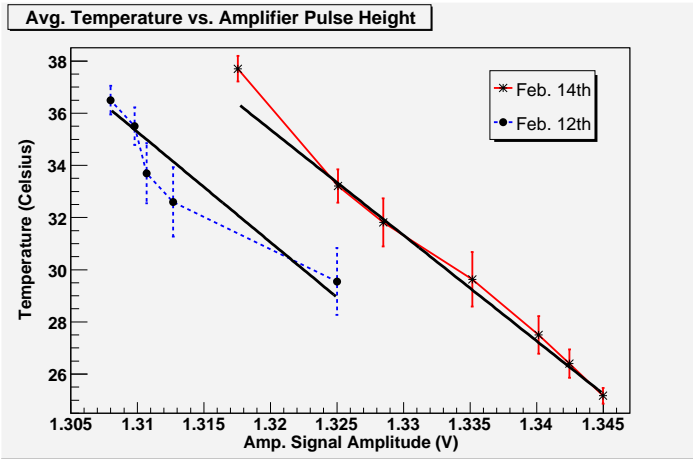

Fig 4: Amplifier fit

temperature measurement then becomes the dominant uncertainty in the data.

Using the two matched sets of heating/cooling data, we plot the inverse relationship (temperature vs. response) in Fig. 4. These data were fit assuming a linear temperature dependence. The vertical error bars are expected to be largely correlated (though the exact correlations are unknown). These correlations were not considered in the fit, effectively increasing the estimate of uncertainties in the slopes. The data collected in the heating/cooling cycles were fit to extract slope parameters. These were then transformed back into response vs. temperature basis and extrapolated to the EE operating temperature of 18 °C. The two measurements were averaged to determine the final result. The gain of amplifier was found to be $(-0.127^{+0.01}_{-0.013})\%$ per °C at 18 °C.

IV. LED Temperature Dependence

A pulser was set to fire the LED at approximately 11 kHz with a pulse width (at fwhm) of 30 ns and an amplitude of 6.1 V (through 50Ω impedance). This produced approximately 120 mV output pulses from the VPT/amplifier. According to the calibration of the amplifier made by RAL, a $6 \cdot 10^{-13}$ Coulombs input gives an output pulse of maximum amplitude 285 mV into 50Ω [3]. Therefore, a 120 mV output corresponds to an injection of $1.6 \cdot 10^6$ electrons. At 0 Tesla, the response of a “typical VPT + BTCP Crystal” should be $\sim 42.5e/\text{MeV}$ [3]. Thus our 120 mV signal equates to an energy of 37.15 GeV in a crystal.

The VPT system was supplied with HV (with the amplifier turned on) and pulsed with the LED for one day before data taking began. This was performed in an

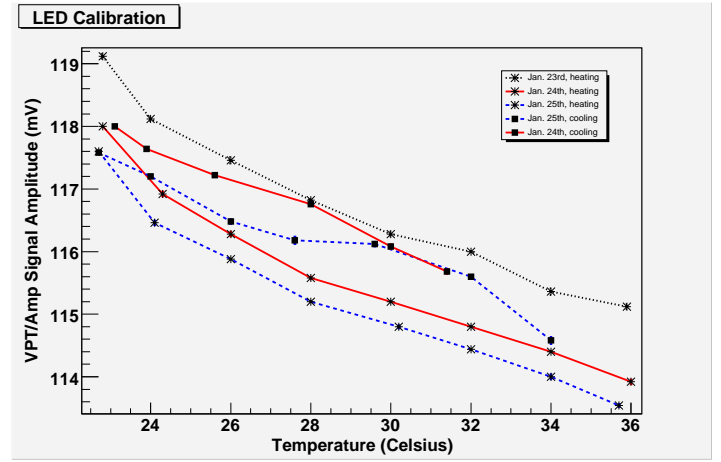

Fig 5: LED response vs. temperature

attempt to allow the VPT signal amplitude to approach a steady value before data taking. After the heaters were turned on, the temperature of the LED increased from about 23 °C to 36 °C over a four hour interval. A couple of hours after the equilibrium temperature was reached the heater was turned off. Periodic measurements were made during the aforementioned interval and during recovery, in which the temperature returned to 23 °C. The temperature of the VPT section of the light proof enclosure was also recorded during data taking and remained at $(24.2 \pm 0.1)^\circ\text{C}$. The width of the single channel VPT signal remained fairly stable at (69.2 ± 0.9) ns.

The pulse height was measured by recording the average peak value of the pulse using the digital oscilloscope. Five sets of measurements were made (see Fig. 5). After applying a linear log likelihood fit for each set of measurements and taking the average of these, the temperature dependence of the LED light yield was found to be $(-0.20 \pm 0.06)\%$ per °C. This result is in good agreement with those given in Ref. [2], where the temperature dependence of the LED's was found to be approximately -0.20% per °C.

V. Temperature Dependence of the Single Channel VPT System

In this measurement, the VPT system was supplied with HV (with the amplifier turned on) and pulsed with the LED for two days before data taking began. This running period was performed in an attempt to allow the VPT/Amp signal amplitude to approach a stable value before data taking began. The LED was driven in the same fashion as in section III. After this leveling period, the VPT signal amplitude was measured as a function of temperature in five separate data sets (see Fig. 6); three sets for VPT/Amp

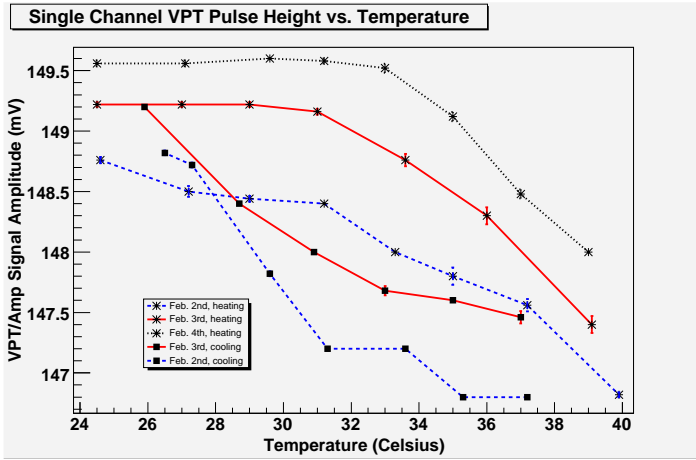

Fig 6: VPT/Amp response vs. temperature

performance under an increase in temperature and two sets during the temperature recovery. The length of each data taking period was approximately 2.5 hours. The average VPT signal amplitude was again measured using the digital oscilloscope. The temperature of the LED section of the light proof enclosure was also recorded during data taking and found to be stable at $(22.6 \pm 0.2)^\circ\text{C}$.

The width of the VPT signal was also measured throughout the temperature range and found to be stable at a value of (67.75 ± 0.75) ns. The data in Fig. 6 show a number of trends. There again appears to be a lag between the measured temperature and the temperature of the electronics. Unexpectedly, we also observe an overall increase in the signal amplitude of each curve on successive days. The cause of this increase in signal has not been identified. But the time scale of any given data set is large compared to the times involved in the individual measurements, so we concentrate on the slopes and not the overall offsets.

The data from two heating/relaxation cycles were fit to determine the temperature dependence of the VPT/Amplifier system using the same procedure described in section II. The distributions used in the fit are shown in Fig. 7 along with the resulting linear fits to the data. Inverting the fit and extrapolating back to 18°C , the temperature dependence of the Single Channel VPT system was found to vary by $(-0.178^{+0.0155}_{-0.022})\%$ per $^\circ\text{C}$ at the EE operating temperature.

VI. Time Dependence of the VPT/Amplifier System

The stability of the amplifier versus time was measured with the heaters off over two time periods. The measurements were obtained using the same method of charge injection described in Section III. The results are

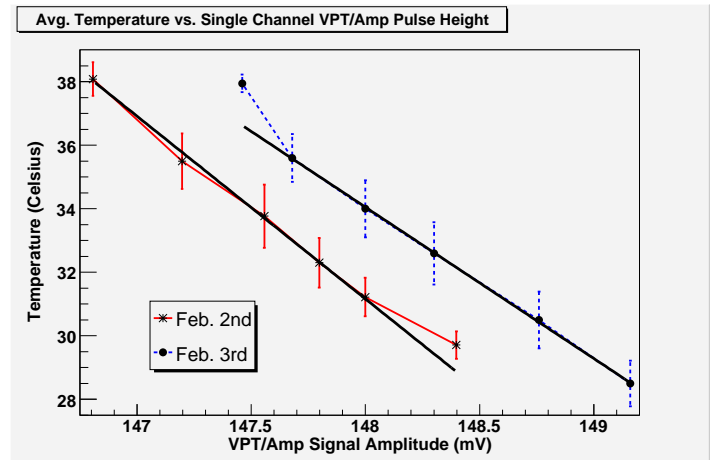

Fig 7: VPT/Amp fit

displayed in Fig. 8. The temperature of the amplifier with the heater off was measured to be $(23.95 \pm 0.15)^\circ\text{C}$ during these measurements. The response of the amplifier was observed to be very stable over time with a standard deviation of about 0.02%.

The performance of the VPT/amplifier system with the heaters off was also observed as a function of time and is displayed in Fig. 9. The entire system was powered down for 48 hours, then the amplitude of the VPT/Amplifier system was monitored for a period of 135 hours. The temperature of the VPT/Amp was measured to be $(23.2 \pm 1.0)^\circ\text{C}$ throughout all measurements and the VPT was pulsed continuously with the LED as described in Section IV. We observe a clear reduction in the signal amplitude and can infer that this is dominated by VPT effects. These observations are in contradiction with the behavior of the signal amplitude in Fig. 6, which shows an increase in amplitude on successive days during the temperature sensitivity measurements. However, these data were taken during a separate running period. We can not rule out a change in the quality of the optical coupling of the fiber to the VPT between (or even within) the various data taking periods. Additional studies need to be performed in order to effectively evaluate these observations.

VII. Results and Discussion

The performance of the single channel VPT/Amplifier system has been monitored in a light-proof environment. We have demonstrated that the signal amplitude of the amplifier remains constant in a steady-state setting as measured by charge injection (Fig. 8). The amplitude of the VPT signal has been shown to degrade with time, but seems to approach a plateau (Fig. 9). An unexpected

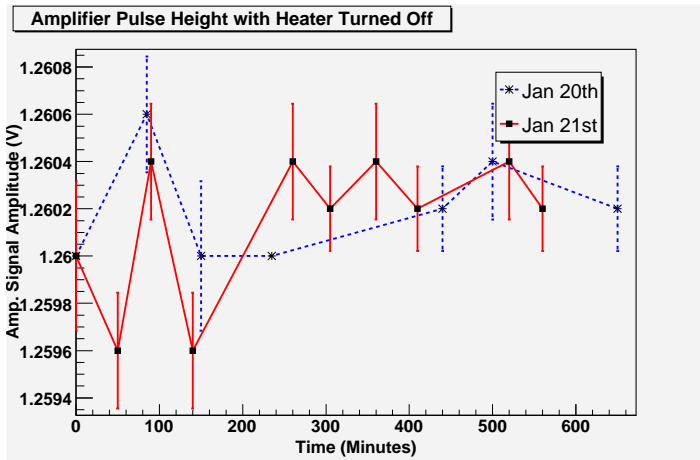

Fig 8: Amplifier stability

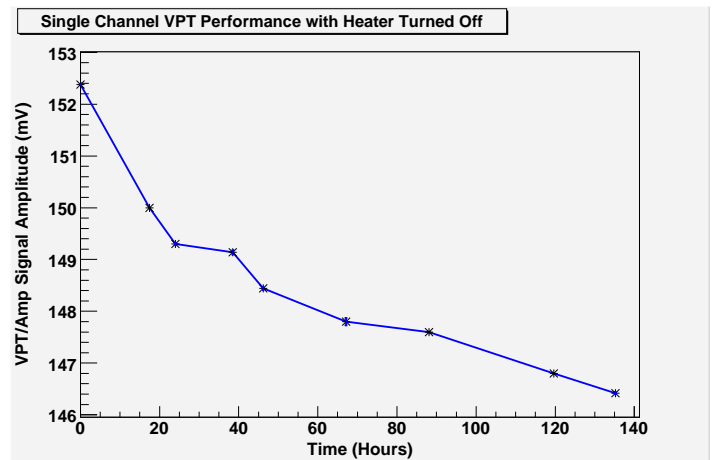

Fig 9: VPT response vs. time

overall increase in response was observed with time during the temperature sensitivity studies (Fig. 6). Possible changes of the LED's luminosity and of the optical coupling at the face of the VPT have not been ruled out in relation to these systematic effects. To extract a more direct measure of the temperature dependence of the system, temperature probes must be located closer to the electronics and/or more time should be allowed for temperature stabilization for each measurement. Additional studies should be performed to provide evidence that the VPT signal amplitude completely levels out over a long period of time and to determine the optimal stabilization time to allow before beginning other measurements on the system. However we believe our studies are reasonably sensitive to transient effects of temperature changes over periods of several hours. Based on the above measurements we estimate the temperature dependence of the Single Channel VPT/Amplifier system to be $(-0.178^{+0.0155}_{-0.022})\%$ per $^{\circ}\text{C}$ at the EE operating temperature.

Acknowledgements

The authors would like to acknowledge the work of RAL (Rutherford Appleton Laboratory) in manufacturing and delivering the single channel VPT device in an expeditious fashion. They also extend their thanks to Dr. P.S. Flower of RAL for many invigorating discussions on the calibration of single channel VPT systems, and to Dr. D.J.A. Cockerill and Dr. R.M. Brown of RAL for their insights into VPT operation.

*To whom correspondence should be addressed.
Electronic Address: dgp6d@virginia.edu

References

- [1] K.W. Bell *et al.*, "Vacuum Phototriodes for the CMS Electromagnetic Calorimeter Endcap," *IEEE Transactions on Nuclear Science*, vol. 51, no. 5, pp. 2284-2287, 2004.
- [2] Part No. RL5-B5515: http://www.superbrightleds.com/specs/b2_specs.htm
- [3] P.S. Flower, "VPT stability and calibration system," 26 May 2006.
- [4] K.W. Bell *et al.*, "The development of vacuum phototriodes for the CMS electromagnetic calorimeter," *Nucl. Instrum. Methods*, vol. A469, pp. 29-46, 2001.
- [5] P.S. Flower, "Notes on the calibration of single channel VPT systems", 15 January 2006.